

# Ezi-STEP<sup>®</sup>

## Micro Stepping System

- Intergrated Controller
- Position Table
- Micro Stepping
- Sensorless Stall Detection
- Software Damping
- Run / Stop Signal Output

**Plus-R**



C **FA** US

**FASTECH**

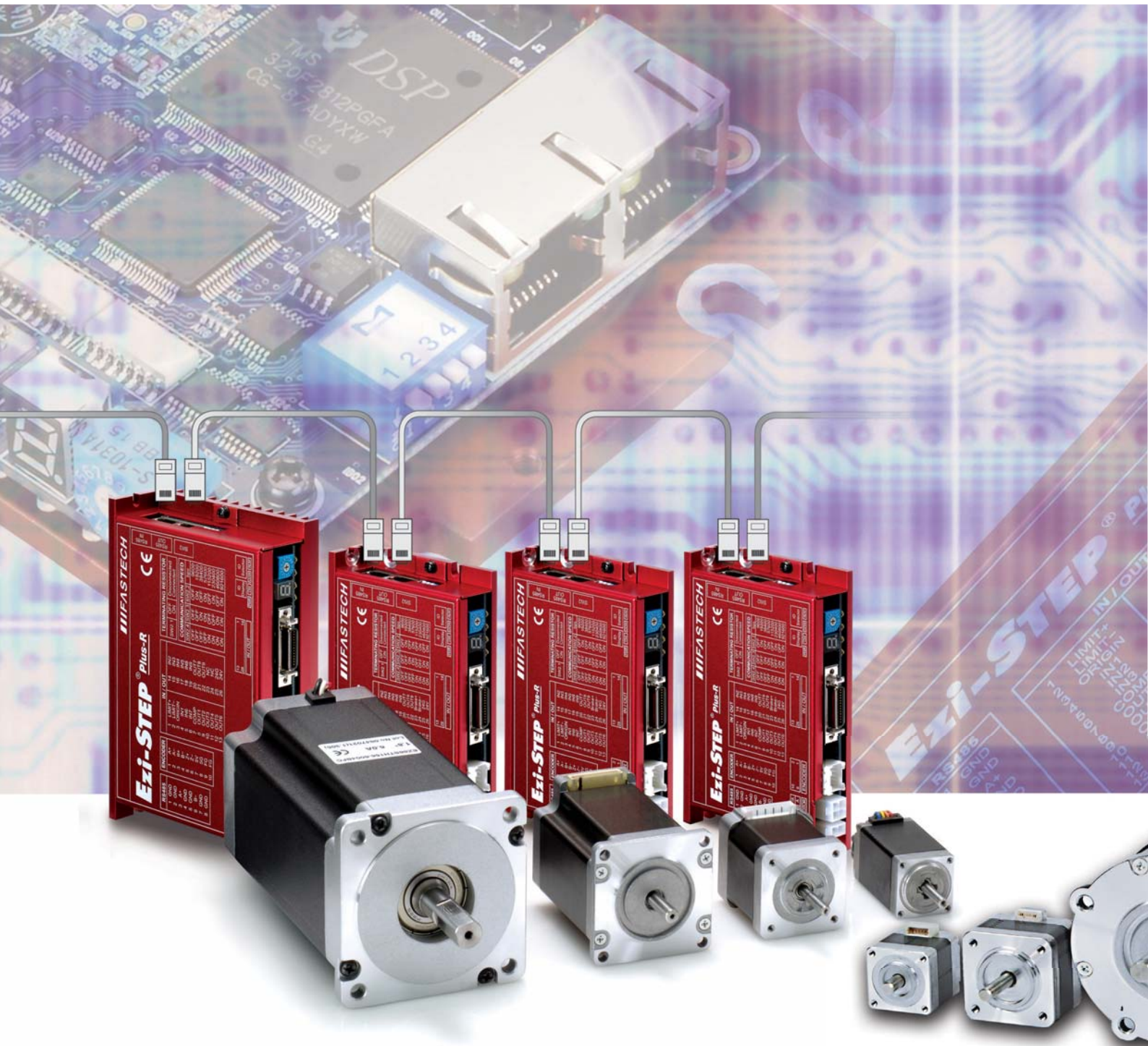

# Ezi-STEP<sup>®</sup> Plus-R

Micro Stepping System  
with Network Based Motion Controller



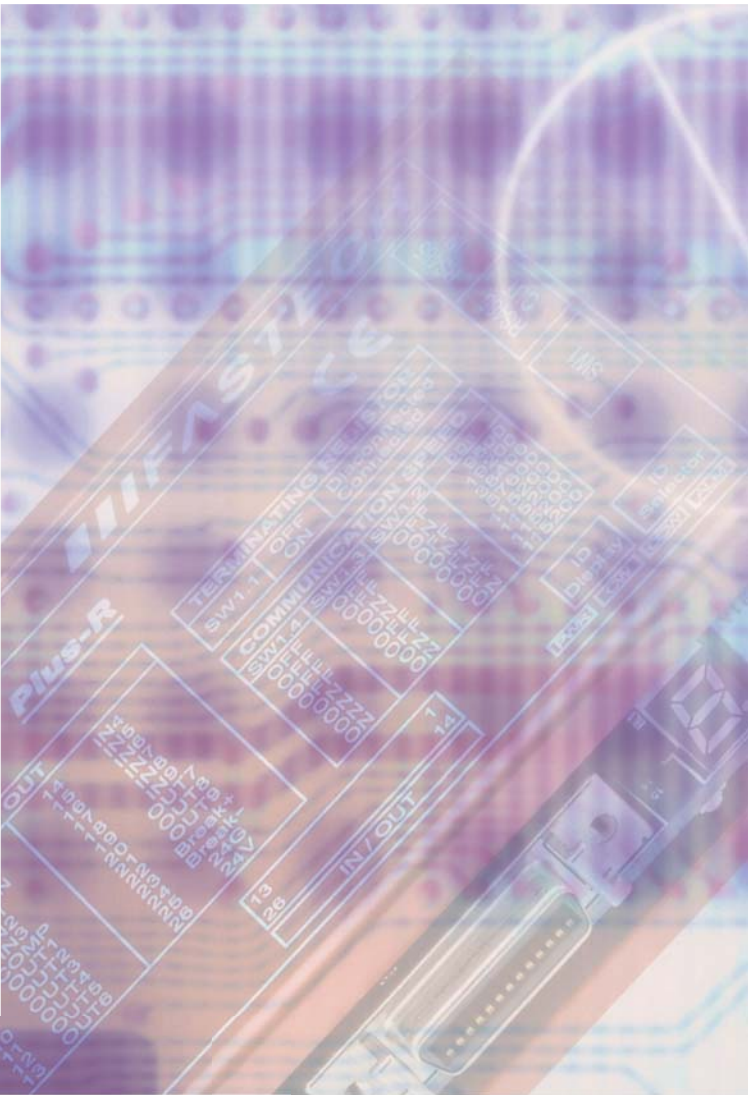

## 1 Network Based Motion Control

A maximum of 16 axis can be operated from a PC through RS-485 communications. All of the Motion conditions are set through the network and saved in Flash ROM as a parameter. Motion Library(DLL) is provided for programming under Windows 2000/XP.

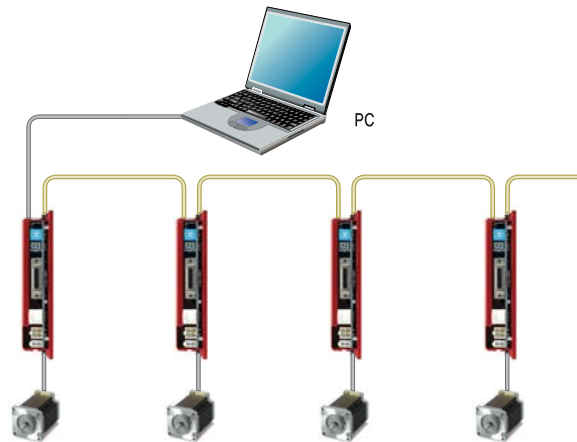

## 2 Position Table Function

Position Table can be used for motion control by digital input and output signals of host controller. You can operate the motor directly by sending the position table number, start/stop, origin search and other digital input values from a PLC.

The PLC can monitor the In-position, origin search, moving/stop, servo ready and other digital output signals from a drive. A maximum of 256 positioning points can be set from PLC.

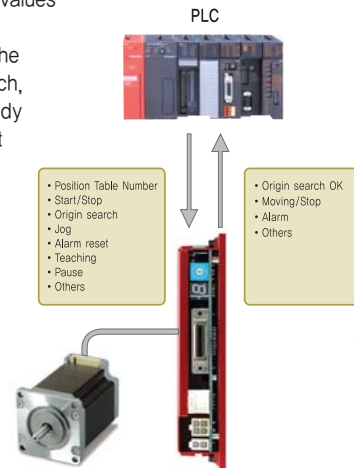

## 3 Microstep and Filtering

### High precision Microstep function and Filtering (Patent pending)

The high-performance DSP operates at step resolutions of  $1.8^\circ$  up to maximum  $0.0072^\circ$  (1/250 steps) and Ezi-STEP<sup>®</sup> adjusts PWM control signal in every  $25\mu$  sec, which makes it possible for more precise current control, resulting in high-precision Microstep operation.

4

**Sensorless Stall Detection**

**Detecting the loss-of-synchronization with on-board DSP(patent pending)**

Ezi-STEP<sup>®</sup> can detect the loss-of-synchronization of a stepping motor without the addition of an external sensor. By monitoring the voltage, current, and back-emf signal, the on-board DSP estimates the current position of a rotor and enables it to detect the loss-of-synchronization (an impossible task for a conventional stepping motor drive), this allows for high-speed operation at 100% torque rating without loss-of-synchronization\*.

\*Effective only over 300 rpm

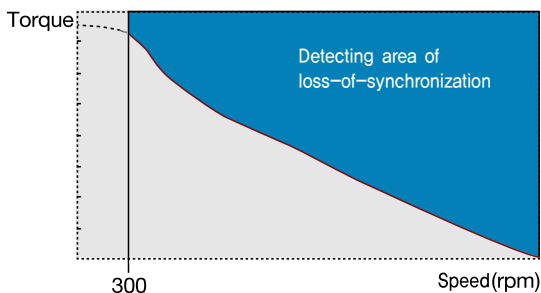

5

**Drive Output Signal Monitoring**

Ezi-STEP<sup>®</sup> provides loss of step, run/stop, over-current, over-heat, over-voltage, power, and motor connection alarms that can be monitored by the controller and visible by a motor-mounted flashing led indicator.

6

**Software Damping**

**Vibration suppression and high-speed operation (Patent pending)**

Vibration suppression and High-speed operation (Patent pending) Motor vibration is created by magnetic flux variations of the motor, lower current from the drive due to back-emf from the motor at high speeds and lowering of phase voltages from the drive.

Ezi-STEP<sup>®</sup> drive detects these problems and the DSP adjusts the phase of the current according to the pole position of the motor, drastically suppressing vibration. This allows the smooth operation of the motor at high speeds.

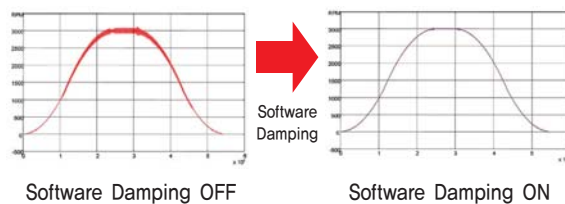

\*This is real measured speed that using 100000[pulse/rev] encoder.

7

**Improvement of High-Speed Driving**

Depending on the speed of a stepping motor, Ezi-STEP<sup>®</sup> automatically increases the supply voltage and prevents the torque lowering due to the low operating voltage to the motor caused by back-emf voltage, this enables high-speed operation. Additionally, the software damping algorithm minimizes the vibration and prevents the loss-of-synchronization at high-speed.

Applicable model : Ezi-STEP-PR-42 Series  
Ezi-STEP-PR-56 Series  
Ezi-STEP-PR-60 Series



# Features of Motion Controller

## 1. Loop Count

This function allows positioning repeatedly according to the Loop Count Number.

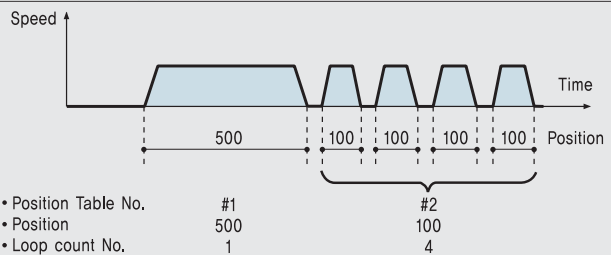

## 2. Acceleration/Deceleration

For quick acceleration and gradual deceleration, you can set each acceleration and deceleration time separately.

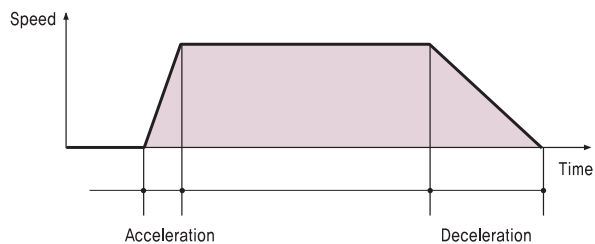

## 3. Pause

You can pause the motion upon the input of an external signal. When Pause signal change to OFF, the motor will restart to original target position.

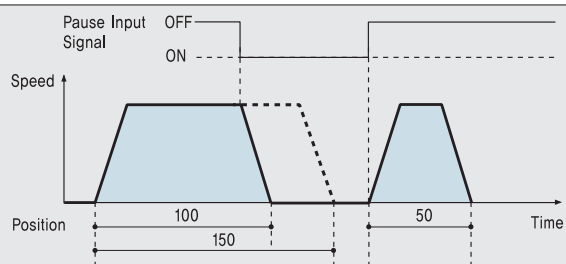

## 4. Alarm

The number of LED flashing time indicates which Alarm has occurred.

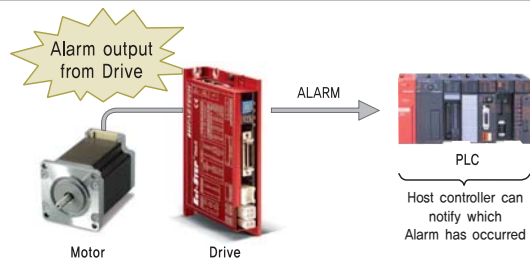

## 5. Teaching

Teaching signal is used to memorize current Position data into the selected Position Table item.

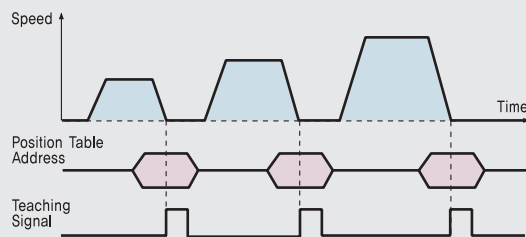

## 6. Jump

Within one Position Table, you can select various Position Table numbers that you want to jump. With three external input signal during movement, the next jump Position Table number can be select.

◆ Position Table #14

Position	---	Next	---	Input 1	Input 2	Input 3	---
10000		100		115	116	117	

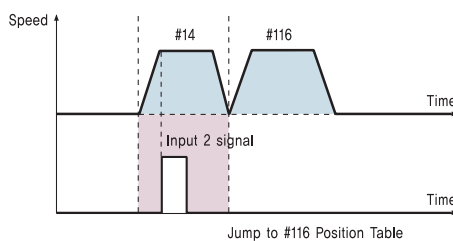
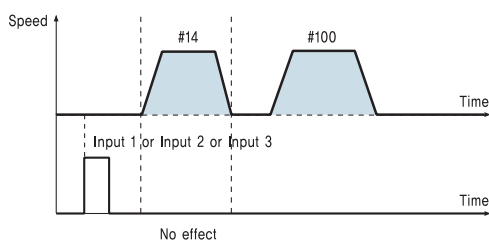

## ● Part Numbering

**Ezi-STEP-PR-42S-□**

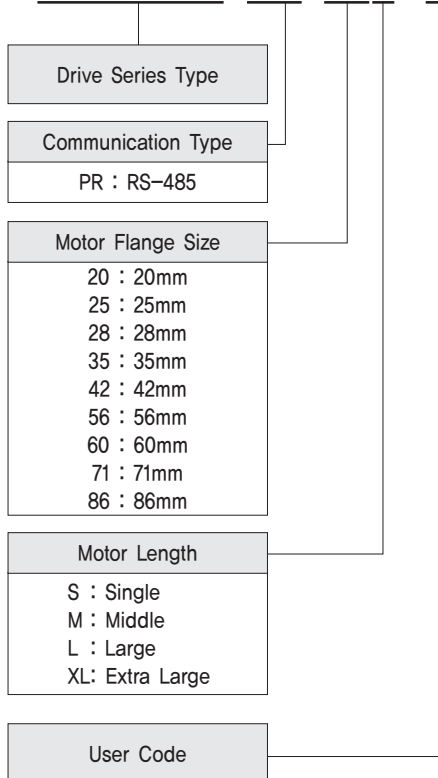

## ● Combination list of Ezi-STEP Plus-R

Unit Part Number	Motor Model Number	Drive Model Number
Ezi-STEP-PR-20M	BM-20M	EzT-NDR-20M
Ezi-STEP-PR-20L	BM-20L	EzT-NDR-20L
Ezi-STEP-PR-25S	BM-25S	EzT-NDR-25S
Ezi-STEP-PR-25M	BM-25M	EzT-NDR-25M
Ezi-STEP-PR-25L	BM-25L	EzT-NDR-25L
Ezi-STEP-PR-28M	BM-28M	EzT-NDR-28M
Ezi-STEP-PR-28L	BM-28L	EzT-NDR-28L
Ezi-STEP-PR-35S	BM-35S	EzT-NDR-35S
Ezi-STEP-PR-35M	BM-35M	EzT-NDR-35M
Ezi-STEP-PR-35L	BM-35L	EzT-NDR-35L
Ezi-STEP-PR-35XL	BM-35XL	EzT-NDR-35XL
Ezi-STEP-PR-42S	BM-42S	EzT-NDR-42S
Ezi-STEP-PR-42M	BM-42M	EzT-NDR-42M
Ezi-STEP-PR-42L	BM-42L	EzT-NDR-42L
Ezi-STEP-PR-42XL	BM-42XL	EzT-NDR-42XL
Ezi-STEP-PR-56S	BM-56S	EzT-NDR-56S
Ezi-STEP-PR-56M	BM-56M	EzT-NDR-56M
Ezi-STEP-PR-56L	BM-56L	EzT-NDR-56L
Ezi-STEP-PR-60S	BM-60S	EzT-NDR-60S
Ezi-STEP-PR-60M	BM-60M	EzT-NDR-60M
Ezi-STEP-PR-60L	BM-60L	EzT-NDR-60L
Ezi-STEP-PR-71M	BM-71M	EzT-NDR-71M
Ezi-STEP-PR-71L	BM-71L	EzT-NDR-71L
Ezi-STEP-PR-86M	BM-86M	EzT-NDR-86M
Ezi-STEP-PR-86L	BM-86L	EzT-NDR-86L
Ezi-STEP-PR-86XL	BM-86XL	EzT-NDR-86XL

## ● Specifications

Motor Model	BM-20 series	BM-25 series	BM-28 series	BM-35 series	BM-42 series	BM-56 series	BM-60 series	BM-71 series	BM-86 series
Driver Model	EzT-NDR-20 series	EzT-NDR-25 series	EzT-NDR-28 series	EzT-NDR-35 series	EzT-NDR-42 series	EzT-NDR-56 series	EzT-NDR-60 series	EzT-NDR-71 series	EzT-NDR-86 series
Input Voltage	24VDC $\pm$ 10%								40~70VDC
Control Method	PWM drive with 32bit DSP								
Multi Axes Drive	Maximum 16 axes through Daisy-Chain								
Position Table	256 motion command steps (Continuous, Wait, Loop, Jump and External start etc.)								
Current Consumption	Max 500mA (Except motor current)								
Operating Condition	Ambient Temperature	In Use : 0~50°C In Storage : -20~70°C							
	Humidity	In Use : 35~85% (Non-condensing) In Storage : 10~90% (Non-condensing)							
	Vib. Resist.	0.5G							
Function	Rotation Speed	0~3000rpm							
	Resolution(P/R)	500, 1000, 1600, 2000, 3200, 3600, 4000, 5000, 6400, 8000, 10000, 20000, 25000, 36000, 40000, 50000 (Selectable by parameter) *Default : 10000							
	Protection Functions	Over current, Over speed, Step out, Over temperature, Over regenerated voltage, Motor connect error, Motor voltage error, System error, ROM error, Input voltage error							
	LED Display	Power, Alarm, CW Rotation, CCW Rotation							
	STOP Current	10%~100% (Selectable by parameter) Current after 0,1 second after motor stop. *Default : 50%							
	Rotational Direction	CW / CCW (Selectable by parameter) Used when changing the direction of motor rotate. *Default : CW							
I/O Signal	Input Signal	3 dedicated input (LIMIT+, LIMIT-, ORIGIN), 9 programmable input (Photocoupler)							
	Output Signal	1 dedicated output (Compare Out), 9 programmable output (Photocoupler), Brake signal							
Communication Interface	The RS-485 serial communication with PC Transmission speed : 9,600~921,600[bps]								
Position Control	Incremental mode / Absolute mode Data Range : -134,217,727 to +134,217,727[pulse], Operating speed : Max. 3000[rpm]								
Return to Origin	Origin Sensor, $\pm$ Limit sensor, Z phase (By external encoder)								
GUI	User Interface Program within Windows								
Software	Motion Library (DLL) for windows 2000/XP								

## ● Drive dimension [mm]

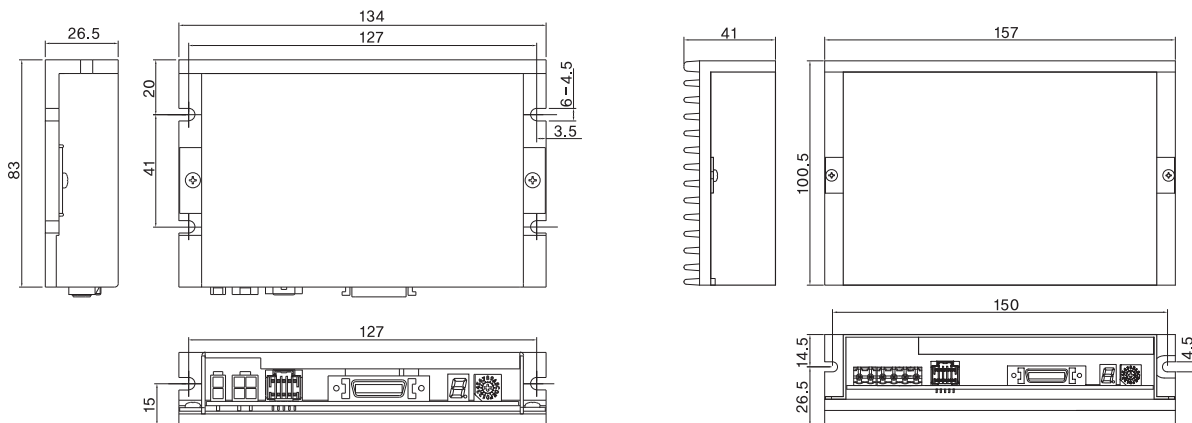

\*Only for 86mm motor drive (EzT-NDR-86 series)

## ● Motor Specifications

M O D E L		UNIT	BM-20M	BM-20L
DRIVE METHOD		----	BI-POLAR	BI-POLAR
NUMBER OF PHASES		----	2	2
VOLTAGE		VDC	2,9	3,25
CURRENT per PHASE		A	0,5	0,5
RESISTANCE per PHASE		Ohm	5,8	6,5
INDUCTANCE per PHASE		mH	2,5	5
HOLDING TORQUE		N · m	0,013	0,025
ROTOR INERTIA		g · cm <sup>2</sup>	2,5	5
WEIGHTS		g	50	80
LENGTH (L)		mm	28	38
ALLOWABLE OVERHUNG LOAD (DISTANCE FROM END OF SHAFT)	3mm	N	18	18
	8mm		30	30
ALLOWABLE THRUST LOAD		N	Lower than motor weight	
INSULATION RESISTANCE		MOhm	100min. (at 500VDC)	
INSULATION CLASS		----	CLASS B (130°C)	
OPERATING TEMPERATURE		°C	0 to 55	

## ● Motor Dimension [mm] and Torque Characteristics

FASTECH Ezi-STEP Plus-R

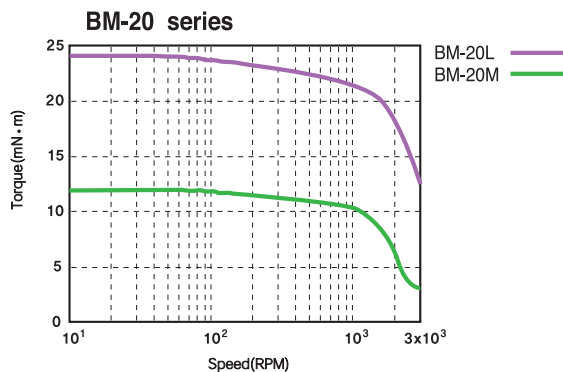
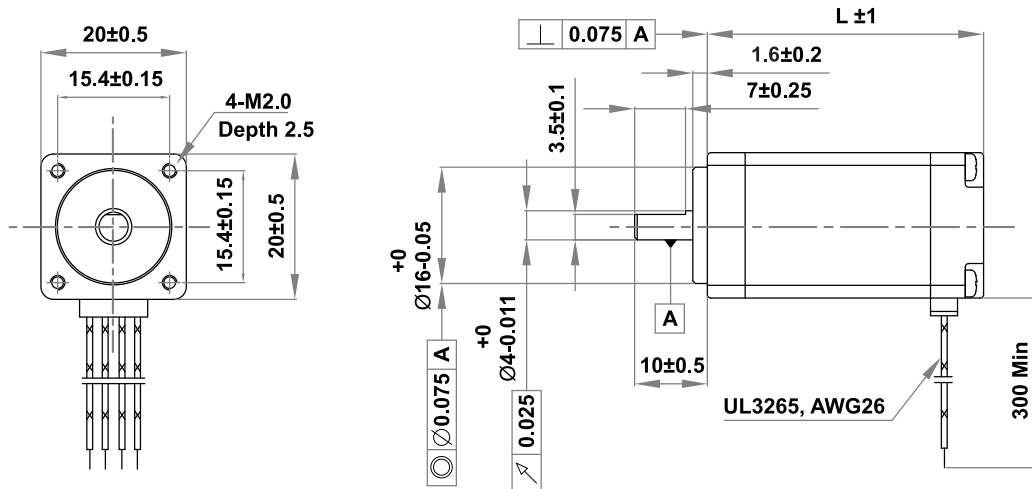

### ※ Measured Condition

Motor Voltage = 24VDC  
 Motor Current = Rated Current (Refer to Motor Specification)  
 Drive = Ezi-STEP-Plus R



## ● Motor Specifications

M O D E L		UNIT	BM-25S	BM-25M	BM-25L
DRIVE METHOD		----	BI-POLAR	BI-POLAR	BI-POLAR
NUMBER OF PHASES		----	2	2	2
VOLTAGE		VDC	2.66	9.87	3.654
CURRENT per PHASE		A	0.7	0.21	0.63
RESISTANCE per PHASE		Ohm	3.8	47	5.8
INDUCTANCE per PHASE		mH	2.0	30	5.4
HOLDING TORQUE		N · m	0.033	0.049	0.062
ROTOR INERTIA		g · cm <sup>2</sup>	2	3	7
WEIGHTS		g	55	70	90
LENGTH (L)		mm	23,5	27,5	33
ALLOWABLE OVERHUNG LOAD (DISTANCE FROM END OF SHAFT)		3mm	30	30	30
		8mm	38	38	38
ALLOWABLE THRUST LOAD		N	Lower than motor weight		
INSULATION RESISTANCE		MOhm	100min. (at 500VDC)		
INSULATION CLASS		----	CLASS B (130°C)		
OPERATING TEMPERATURE		°C	0 to 55		

## ● Motor Dimension [mm] and Torque Characteristics

- LEAD WIRE
  - HOUSING : 51021-0600
  - PIN : 50079-8000
  - LENGHT : 300mm MIN

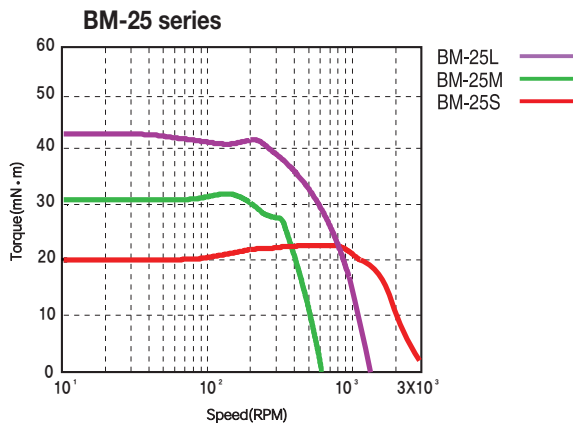
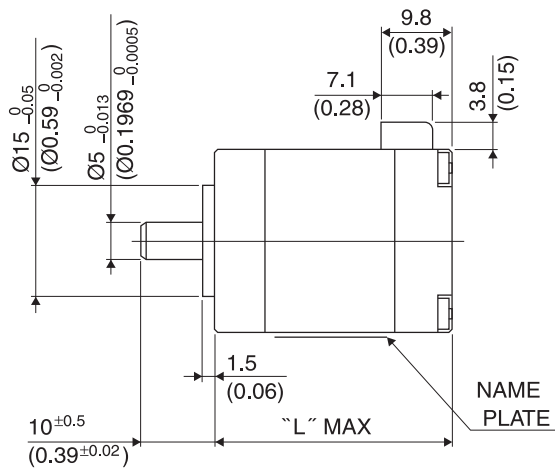
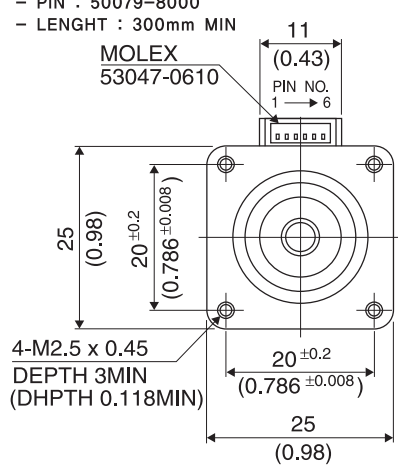

### ※ Measured Condition

Motor Voltage = 24VDC

Motor Current = Rated Current(Refer to Motor Specification)

Drive = Ezi-STEP-Plus R

## ● Motor Specifications

M O D E L		UNIT	BM-28S	BM-28M	BM-28L
DRIVE METHOD		----	BI-POLAR	BI-POLAR	BI-POLAR
NUMBER OF PHASES		----	2	2	2
VOLTAGE		VDC	3,04	3,04	3,42
CURRENT per PHASE		A	0,95	0,95	0,95
RESISTANCE per PHASE		Ohm	3,2	3,2	3,6
INDUCTANCE per PHASE		mH	2	5	5,8
HOLDING TORQUE		N · m	0,065	0,08	0,11
ROTOR INERTIA		g · cm <sup>2</sup>	9	13	18
WEIGHTS		g	110	140	200
LENGTH (L)		mm	32	45	52
ALLOWABLE OVERHUNG LOAD (DISTANCE FROM END OF SHAFT)	3mm	N	30	30	30
	8mm		38	38	38
	13mm		53	53	53
	18mm		84	84	84
ALLOWABLE THRUST LOAD		N	Lower than motor weight		
INSULATION RESISTANCE		MOhm	100min, (at 500VDC)		
INSULATION CLASS		----	CLASS B (130°C)		
OPERATING TEMPERATURE		°C	0 to 55		

## ● Motor Dimension [mm] and Torque Characteristics

FASTECH Ezi-STEP Plus-R

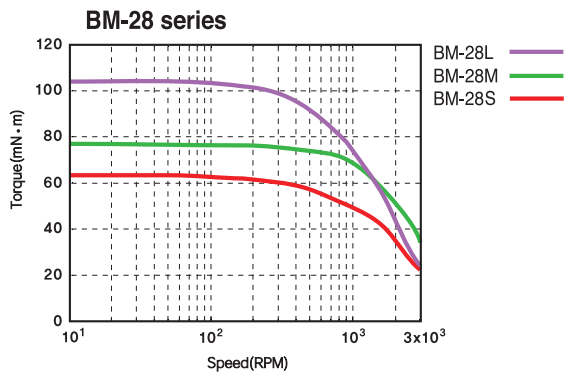
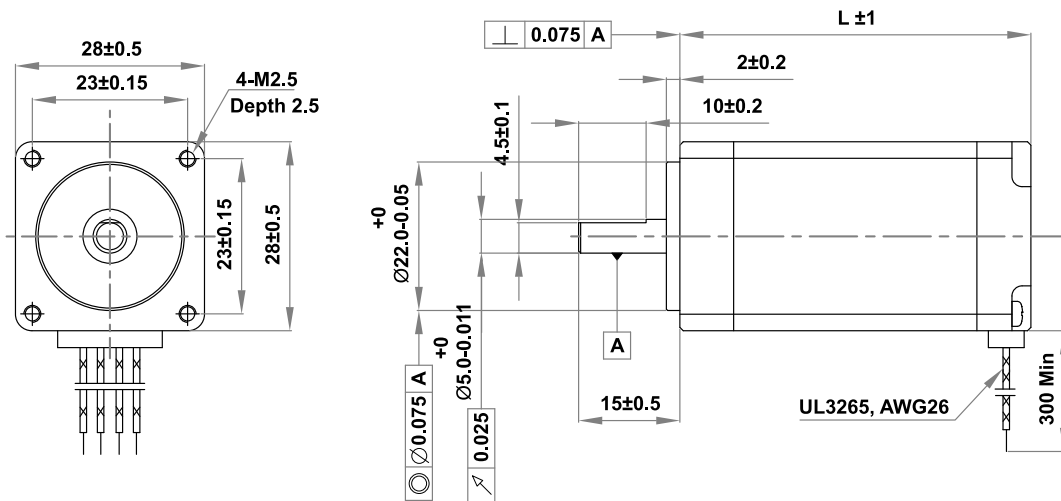

### ※Measured Condition

Motor Voltage = 24VDC  
 Motor Current = Rated Current (Refer to Motor Specification)  
 Drive = Ezi-STEP-Plus R

## ● Motor Specifications

MODEL		UNIT	BM-35S	BM-35M	BM-35L	BM-35XL
DRIVE METHOD		----	BI-POLAR	BI-POLAR	BI-POLAR	BI-POLAR
NUMBER OF PHASES		----	2	2	2	2
VOLTAGE		VDC	2,28	2,88	4,59	5,39
CURRENT per PHASE		A	0,6	0,6	0,85	0,7
RESISTANCE per PHASE		Ohm	3,8	4,8	5,4	7,7
INDUCTANCE per PHASE		mH	3,2	6,1	6,5	8,4
HOLDING TORQUE		N · m	0,034	0,050	0,176	0,225
ROTOR INERTIA		g · cm <sup>2</sup>	5	8	11	32
WEIGHTS		g	105	120	200	300
LENGTH (L)		mm	22	26	38	535
ALLOWABLE OVERHUNG LOAD (DISTANCE FROM END OF SHAFT)	3mm	N	22	22	22	22
	8mm		26	26	26	26
	13mm		33	33	33	33
	18mm		46	46	46	46
ALLOWABLE THRUST LOAD		N	Lower than motor weight			
INSULATION RESISTANCE		MOhm	100min. (at 500VDC)			
INSULATION CLASS		----	CLASS B (130°C)			
OPERATING TEMPERATURE		°C	0 to 55			

## ● Motor Dimension [mm] and Torque Characteristics

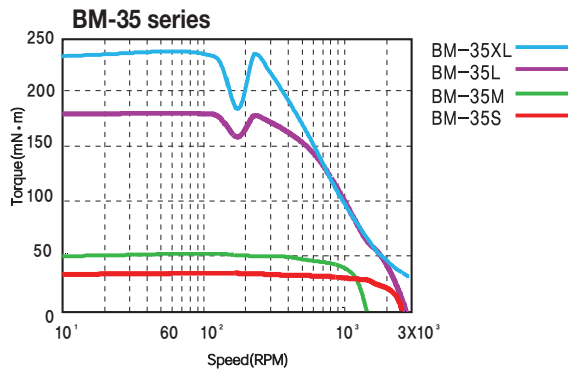
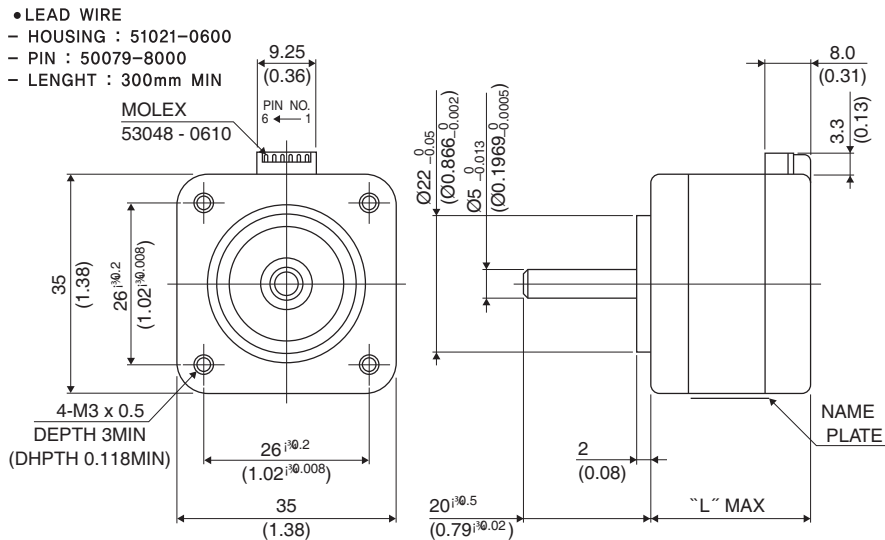

※Measured Condition

Motor Voltage = 24VDC  
 Motor Current = Rated Current(Refer to Motor Specification)  
 Drive = Ezi-STEP-Plus R

## ● Motor Specifications

MODEL		UNIT	BM-42S	BM-42M	BM-42L	BM-42XL
DRIVE METHOD		----	BI-POLAR	BI-POLAR	BI-POLAR	BI-POLAR
NUMBER OF PHASES		----	2	2	2	2
VOLTAGE		VDC	3,36	4,32	4,56	7,2
CURRENT per PHASE		A	1,2	1,2	1,2	1,2
RESISTANCE per PHASE		Ohm	2,8	3,6	3,8	6
INDUCTANCE per PHASE		mH	2,5	7,2	8	15,6
HOLDING TORQUE		N · m	0,32	0,44	0,5	0,65
ROTOR INERTIA		g · cm <sup>2</sup>	35	54	77	114
WEIGHTS		g	220	280	350	500
LENGTH (L)		mm	33	39	47	59
ALLOWABLE OVERHUNG LOAD (DISTANCE FROM END OF SHAFT)	3mm	N	22	22	22	22
	8mm		26	26	26	26
	13mm		33	33	33	33
	18mm		46	46	46	46
ALLOWABLE THRUST LOAD		N	Lower than motor weight			
INSULATION RESISTANCE		MOhm	100min. (at 500VDC)			
INSULATION CLASS		----	CLASS B (130°C)			
OPERATING TEMPERATURE		°C	0 to 55			

## ● Motor Dimension [mm] and Torque Characteristics

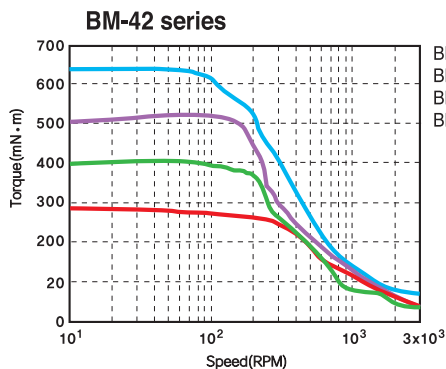
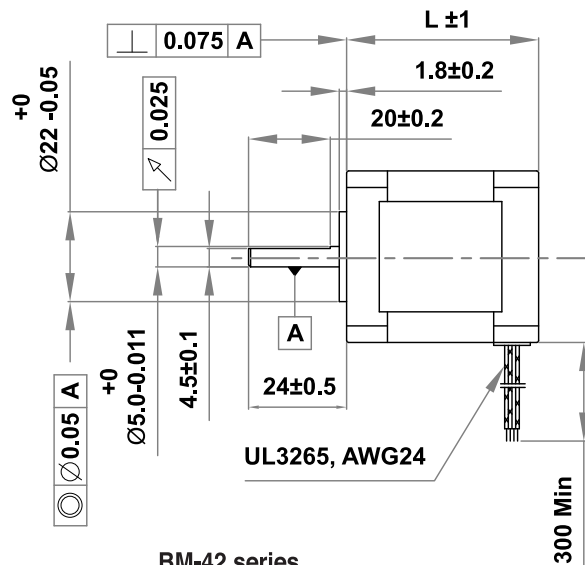
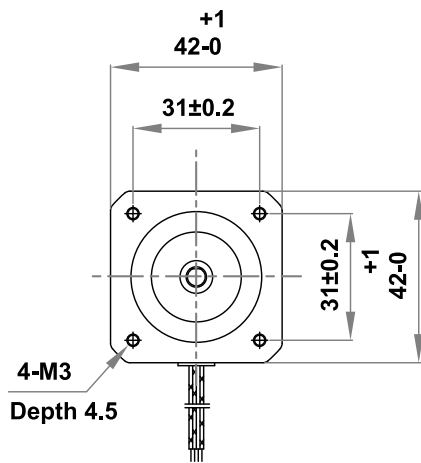

※ Measured Condition

Motor Voltage = 24VDC  
Motor Current = Rated Current (Refer to Motor Specification)  
Drive = Ezi-STEP-Plus R

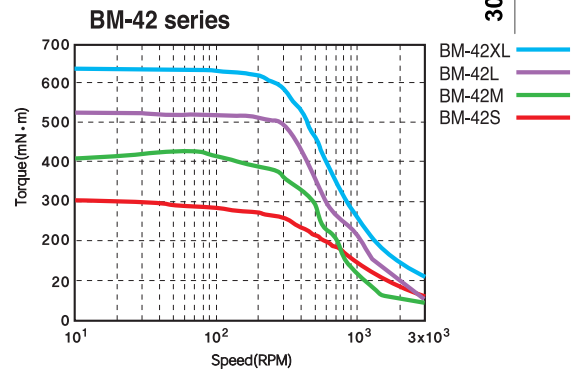

※ Measured Condition

Motor Voltage = 40VDC  
Motor Current = Rated Current (Refer to Motor Specification)  
Drive = Ezi-STEP-Plus R



## ● Motor Specifications

MODEL		UNIT	BM-56S	BM-56M	BM-56L
DRIVE METHOD		----	BI-POLAR	BI-POLAR	BI-POLAR
NUMBER OF PHASES		----	2	2	2
VOLTAGE		VDC	1,56	1,62	2,7
CURRENT per PHASE		A	3	3	3
RESISTANCE per PHASE		Ohm	0,52	0,54	0,9
INDUCTANCE per PHASE		mH	1	2	3,8
HOLDING TORQUE		N · m	0,64	1	1,5
ROTOR INERTIA		g · cm <sup>2</sup>	120	200	480
WEIGHTS		g	500	700	1150
LENGTH (L)		mm	46	54	80
ALLOWABLE OVERHUNG LOAD (DISTANCE FROM END OF SHAFT)	3mm	N	52	52	52
	8mm		65	65	65
	13mm		85	85	85
	18mm		123	123	123
ALLOWABLE THRUST LOAD		N	Lower than motor weight		
INSULATION RESISTANCE		MOhm	100min, (at 500VDC)		
INSULATION CLASS		----	CLASS B (130°C)		
OPERATING TEMPERATURE		°C	0 to 55		

## ● Motor Dimension [mm] and Torque Characteristics

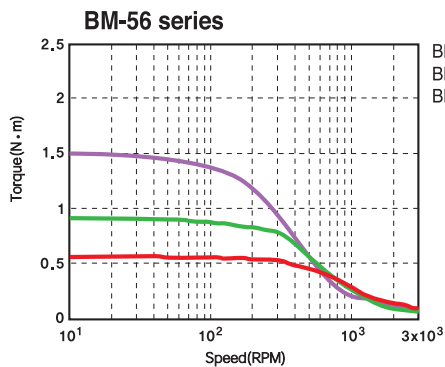
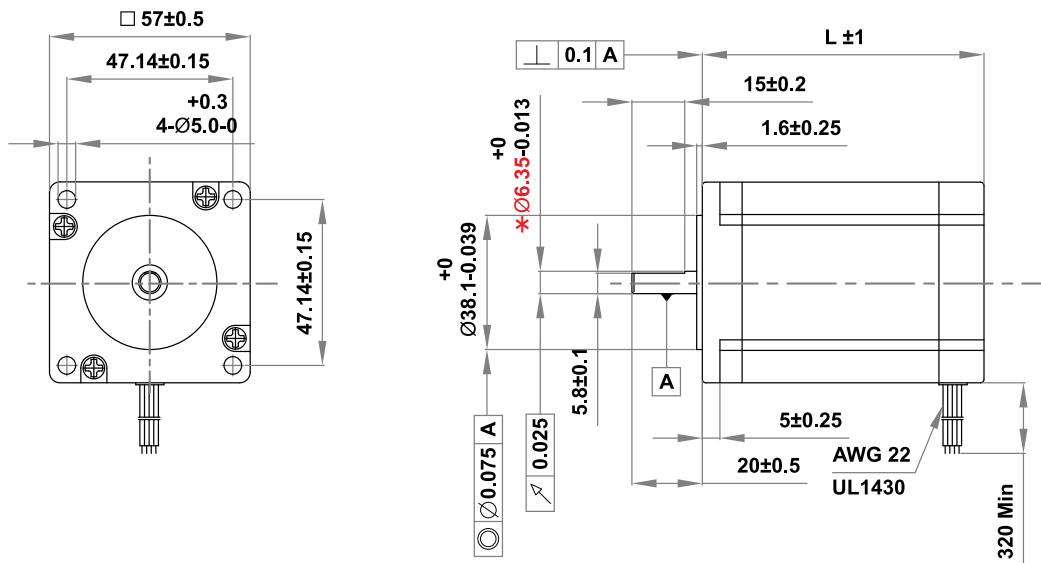

※ Measured Condition  
 Motor Voltage = 24VDC  
 Motor Current = Rated Current (Refer to Motor Specification)  
 Drive = Ezi-STEP-Plus R

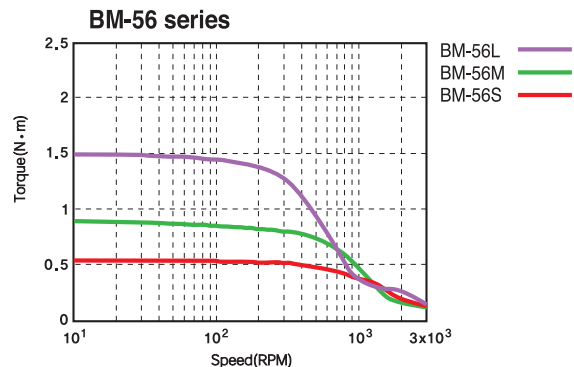

※ Measured Condition  
 Motor Voltage = 40VDC  
 Motor Current = Rated Current (Refer to Motor Specification)  
 Drive = Ezi-STEP-Plus R

\* : There are 2 kinds size of front shaft diameter for BM-56 series as  $\varnothing 6,35$  and  $\varnothing 8,0$ .

## ● Motor Specifications

M O D E L		UNIT	BM-60S	BM-60M	BM-60L
DRIVE METHOD		----	BI-POLAR	BI-POLAR	BI-POLAR
NUMBER OF PHASES		----	2	2	2
VOLTAGE		VDC	1,52	1,56	2,6
CURRENT per PHASE		A	4	4	4
RESISTANCE per PHASE		Ohm	0,38	0,39	0,65
INDUCTANCE per PHASE		mH	0,64	1,2	2,4
HOLDING TORQUE		N · m	0,88	1,28	2,4
ROTOR INERTIA		g · cm <sup>2</sup>	140	320	800
WEIGHTS		g	600	900	1600
LENGTH (L)		mm	46	56	90
ALLOWABLE OVERHUNG LOAD (DISTANCE FROM END OF SHAFT)	3mm	N	70	70	70
	8mm		87	87	87
	13mm		114	114	114
	18mm		165	165	165
ALLOWABLE THRUST LOAD		N	Lower than motor weight		
INSULATION RESISTANCE		MOhm	100min, (at 500VDC)		
INSULATION CLASS		----	CLASS B (130°C)		
OPERATING TEMPERATURE		°C	0 to 55		

## ● Motor Dimension [mm] and Torque Characteristics

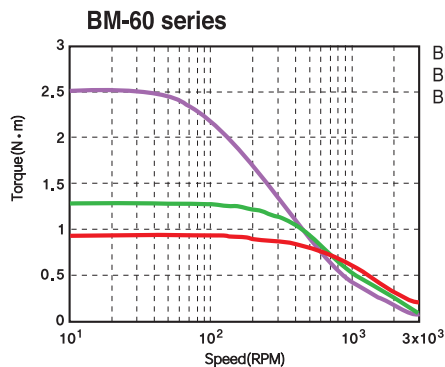
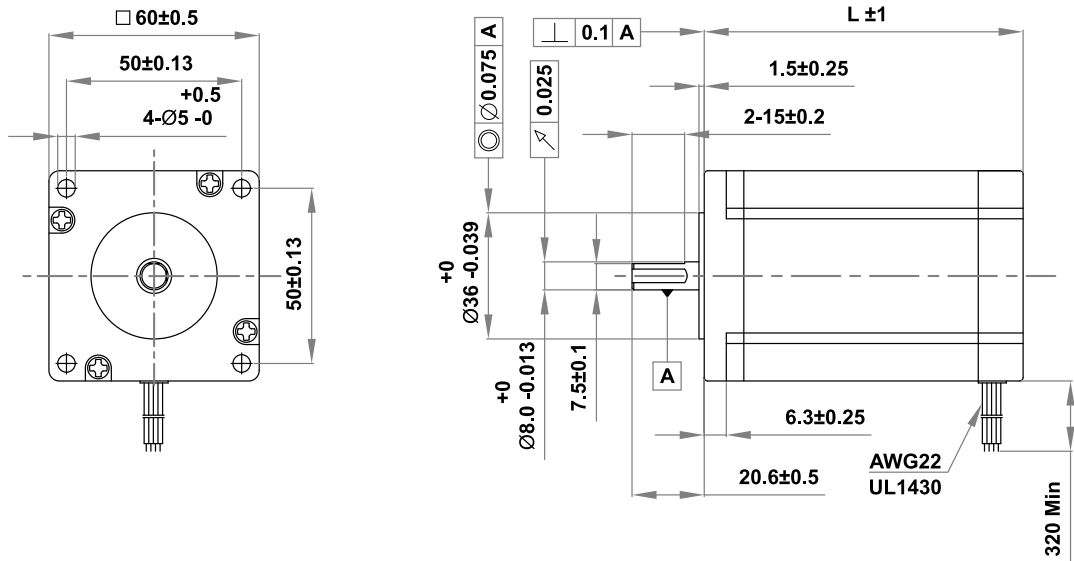

※ Measured Condition

Motor Voltage = 24VDC  
 Motor Current = Rated Current (Refer to Motor Specification)  
 Drive = Ezi-STEP-Plus R

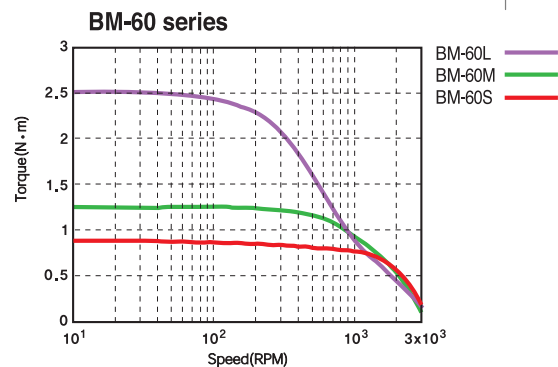

※ Measured Condition

Motor Voltage = 40VDC  
 Motor Current = Rated Current (Refer to Motor Specification)  
 Drive = Ezi-STEP-Plus R

## ● Motor Specifications

MODEL		UNIT	BM-71M	BM-71L
DRIVE METHOD		----	BI-POLAR	BI-POLAR
NUMBER OF PHASES		----	2	2
VOLTAGE		VDC	4.68	4.4
CURRENT per PHASE		A	1.3	2.2
RESISTANCE per PHASE		Ohm	3.6	2
INDUCTANCE per PHASE		mH	11	8.3
HOLDING TORQUE		N · m	1.1	2.1
ROTOR INERTIA		g · cm <sup>2</sup>	330	660
WEIGHTS		Kg	820	1390
LENGTH (L)		mm	51.5	77.5
ALLOWABLE OVERHUNG LOAD (DISTANCE FROM END OF SHAFT)	3mm	N	70	70
	8mm		87	87
	13mm		114	114
	18mm		165	165
ALLOWABLE THRUST LOAD		N	Lower than motor weight	
INSULATION RESISTANCE		MOhm	100min. (at 500VDC)	
INSULATION CLASS		----	CLASS B (130°C)	
OPERATING TEMPERATURE		°C	0 to 55	

## ● Motor Dimension [mm] and Torque Characteristics

● LEAD WIRE

- HOUSING : 51021-0600
- PIN : 50079-8000
- LENGTH : 300mm MIN
- JST
- S8B-PHDSS

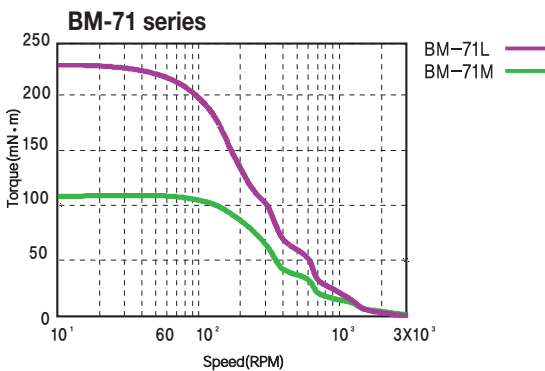
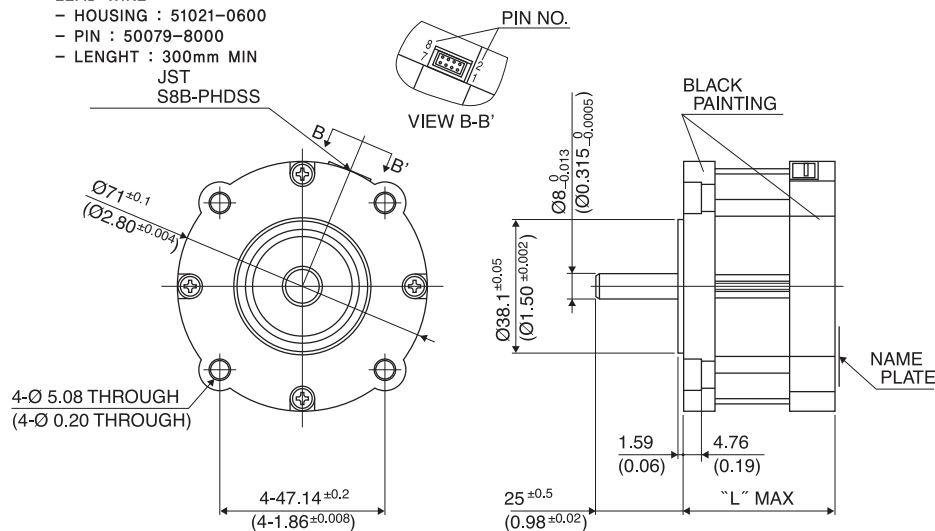

※ Measured Condition

Motor Voltage = 24VDC  
 Motor Current = Rated Current (Refer to Motor Specification)  
 Drive = Ezi-STEP-Plus R

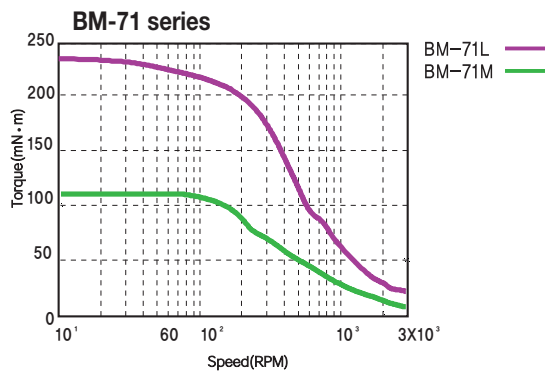

※ Measured Condition

Motor Voltage = 40VDC  
 Motor Current = Rated Current (Refer to Motor Specification)  
 Drive = Ezi-STEP-Plus R

\* 56mm and 71mm stepper' s mounting position is same which can be cross-compatible for mounting

## ● Motor Specifications

MODEL		UNIT	BM-86M	BM-86L	BM-86XL
DRIVE METHOD		----	BI-POLAR	BI-POLAR	BI-POLAR
NUMBER OF PHASES		----	2	2	2
VOLTAGE		VDC	2.4	3.6	4.38
CURRENT per PHASE		A	6	6	6
RESISTANCE per PHASE		Ohm	0.4	0.6	0.73
INDUCTANCE per PHASE		mH	3.5	6.5	8.68
HOLDING TORQUE		N · m	4.0	7.5	9.0
ROTOR INERTIA		g · cm <sup>2</sup>	1400	2700	4000
WEIGHTS		Kg	2.3	3.8	5.3
LENGTH (L)		mm	79	117	155
ALLOWABLE OVERHUNG LOAD (DISTANCE FROM END OF SHAFT)	3mm	N	270	270	270
	8mm		300	300	300
	13mm		350	350	350
	18mm		400	400	400
ALLOWABLE THRUST LOAD		N	Lower than motor weight		
INSULATION RESISTANCE		MOhm	100min, (at 500VDC)		
INSULATION CLASS		----	CLASS B (130°C)		
OPERATING TEMPERATURE		°C	0 to 55		

## ● Motor Dimension [mm] and Torque Characteristics

FASTECH Ezi-STEP Plus-R

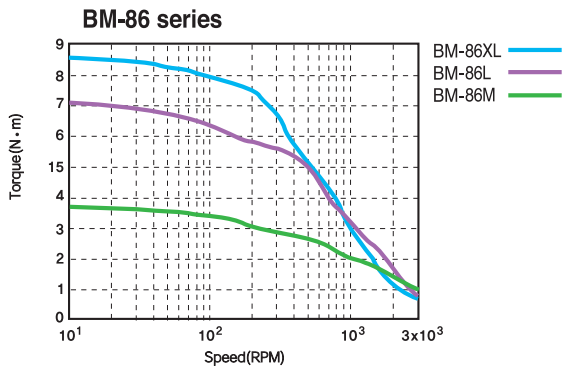
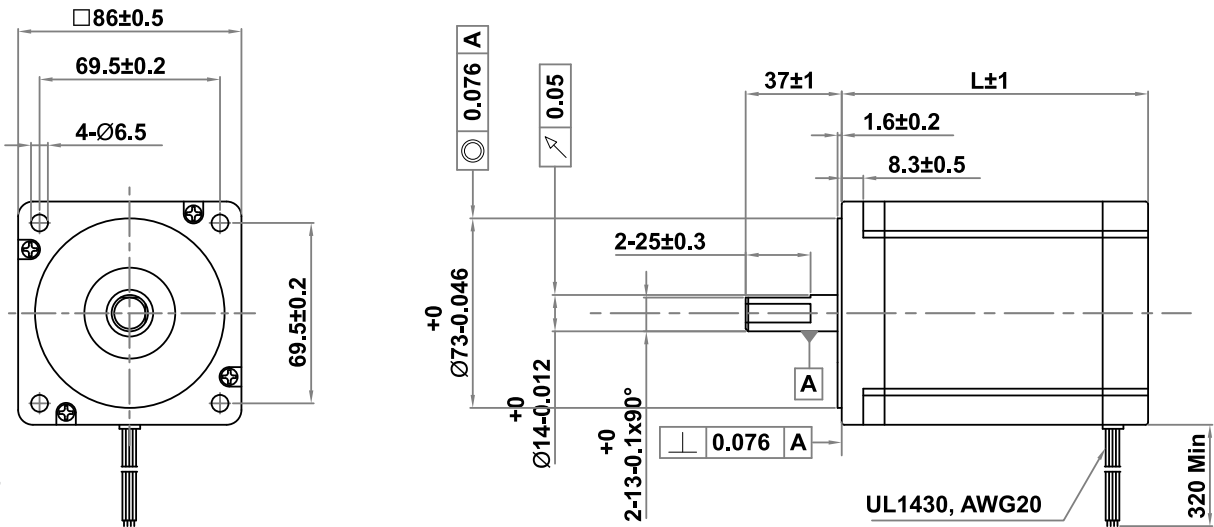

※ Measured Condition

Motor Voltage = 70VDC  
 Motor Current = Rated Current (Refer to Motor Specification)  
 Drive = Ezi-STEP-Plus R



## ● Setting and Operating

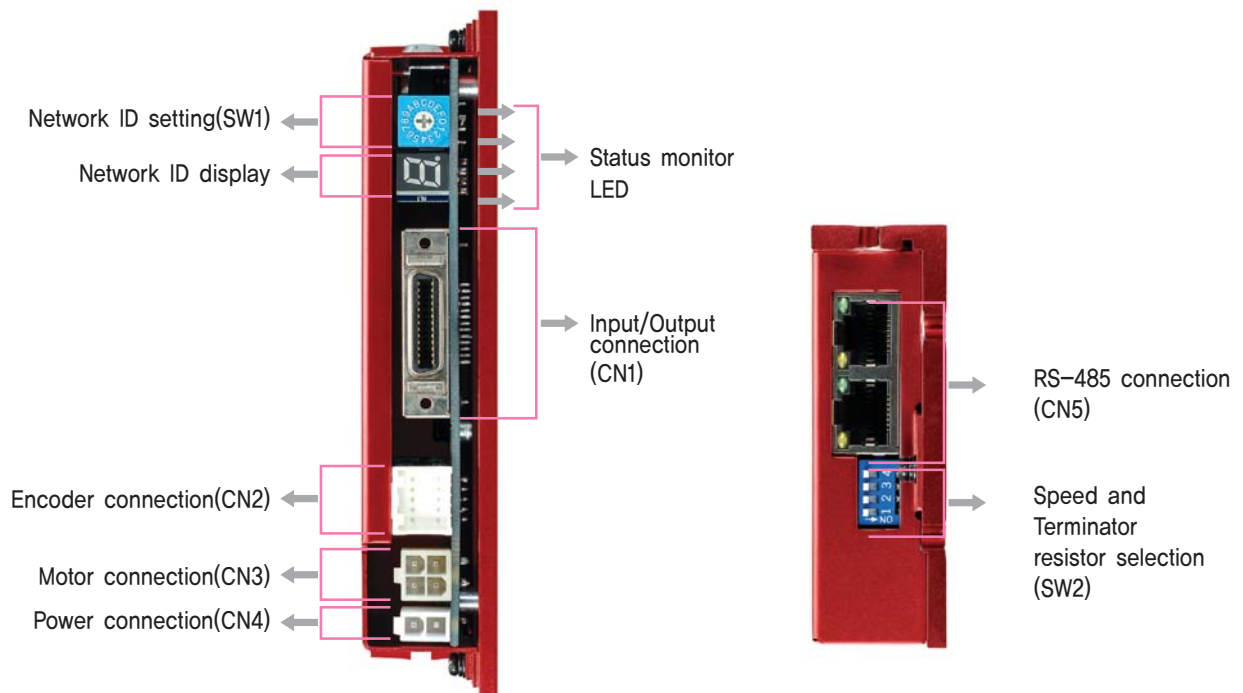

### ◆ 86mm motor drive only(EzT-NDR-86 Series)

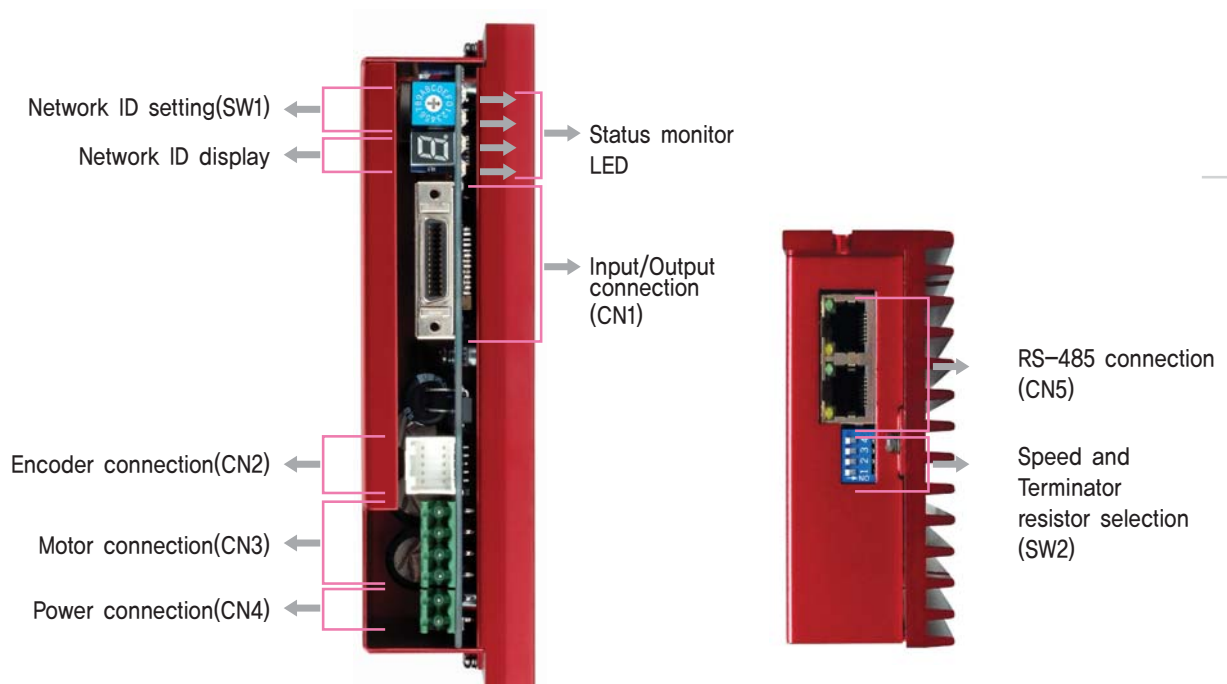

## 1. Status Monitor LED

Indication	Color	Function	ON/OFF Condition
PWR	Green	Power input indication	Lights when power is ON Flashes when motor is Free status
ALM	Red	Alarm indication	Flash when protection function is activated (Identifiable which protection mode is activated by counting the blinking times)
CW	Yellow	Motor Rotation Direction	Lights when motor rotate CW direction
CCW	Orange	Motor Rotation Direction	Lights when motor rotate CCW direction

### ◆ Protection functions and LED flash times

Times	Protection	Conditions
1	Over current	The current through power devices in inverter exceeds the limit value
2	Over speed	Motor speed exceed 3000rpm
3	Step out	Abnormally motor do not followed pulsed input
5	Over temperature	Inside temperature of drive exceeds 55°C
6	Over regenerative voltage	Back-EMF more high limit value*1
7	Motor connect error	The power is ON without connection of the motor cable to drive
9	Motor voltage error	Motor voltage is out of limited value*2
11	System error	Error occurs in drive system
12	ROM error	Error occurs in parameter storage device(ROM)
14	Input voltage error	Power source voltage is out of limited value*3

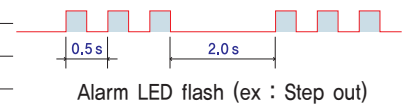

- \*1 : Voltage limit of Back-EMF depends on motor model (Refer to the Manual)
- \*2 : Motor limit voltage value depends on motor model (Refer to the Manual)
- \*3 : Limit value provided to drives depends on driver model (Refer to the Manual)

## 2. Network ID selection switch(SW1)

Position	ID number	Position	ID number
0	0	8	8
1	1	9	9
2	2	A	10
3	3	B	11
4	4	C	12
5	5	D	13
6	6	E	14
7	7	F	15



\*Maximum 16 axis can be connected in one network.

## 3. Speed and Terminator resistor selection switch(SW2)

The purpose of this is to setting the communication speed and connect a terminator resistor if drive is installed at the end of network.

SW 2.1 used for connecting the terminator resistor.  
SW 2.2~SW 2.4 used for setting speed as follows.

SW 2.1	SW 2.2	SW 2.3	SW 2.4	Baud rate[bps]
–	OFF	OFF	OFF	9600
–	ON	OFF	OFF	19200
–	OFF	ON	OFF	38400
–	ON	ON	OFF	57600
–	OFF	OFF	ON	115200*1
–	ON	OFF	ON	230400
–	OFF	ON	ON	460800
–	ON	ON	ON	921600

\*1 : Default setting value

If SW2.1 is OFF, terminator resistor is disconnected.  
If SW2.2 is ON, terminator resistor is connected.

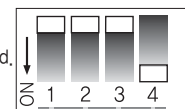

#### 4. Input/Output signal(CN1)

NO.	Function	I/O
1	LIMIT+	Input
2	LIMIT-	Input
3	ORIGIN	Input
4	Digital In1	Input
5	Digital In6	Input
6	Digital In7	Input
7	Compare Out1	Output
8	Digital Out1	Output
9	Digital Out2	Output
10	Digital Out3	Output
11	Digital Out4	Output
12	Digital Out5	Output
13	Digital Out6	Output
14	Digital In2	Input
15	Digital In3	Input
16	Digital In4	Input
17	Digital In5	Input
18	Digital In8	Input
19	Digital In9	Input
20	Digital Out7	Output
21	Digital Out8	Output
22	Digital Out9	Output
23	BRAKE+	Output
24	BRAKE-	Output
25	24VDC GND	Input
26	24VDC	Input

※BRAKE function is optional.

※There is no BRAKE function for 86mm motor drive.

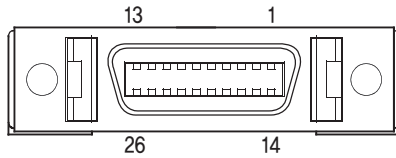

#### 5. Encoder connector(CN2)

NO.	Function	I/O
1	A+	Input
2	A-	Input
3	B+	Input
4	B-	Input
5	Z+	Input
6	Z-	Input
7	5VDC	Output
8	5VDC GND	Output
9	Frame GND	----
10	Frame GND	----

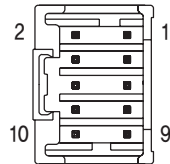

※Used for monitoring the external encoder signal.

#### 6. Motor connector(CN3)

NO.	Function
1	A Phase
2	B Phase
3	/A Phase
4	/B Phase



NO.	Function
1	/B Phase
2	B Phase
3	/A Phase
4	A Phase

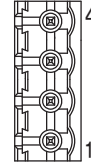

※Only for 86mm motor drive.

#### 7. Power connector(CN4)

NO.	Function
1	24VDC ±10%
2	GND



NO.	Function
1	GND
2	40~70VDC

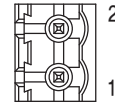

※Only for 86mm motor drive.

#### 8. RS-485 Communication connector(CN5)

There is converter for connecting PC.

##### 1)RS-232 to RS-485

NO.	Function	NO.	Function
1	GND	6	Data-
2	GND	7	GND
3	Data+	8	GND
4	GND	LED 1, 3	Drive status
5	GND	LED 2, 4	Communication status

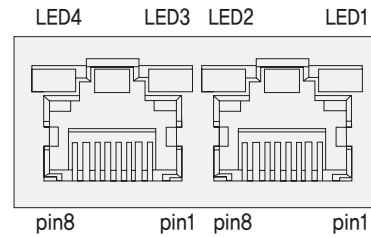

## ◆ Connector for Cabling

These connectors are serviced together with Ezi-STEP Plus-R except when purchasing option cables.

### CN1 : Input/Output Connector

Item	Specification	Maker
Connector	10126-3000PE	3M
Shell	10326-52FO-008	3M

### CN2 : Encoder Connector

Item	Specification	Maker
Housing	51353-1000	MOLEX
Terminal	56134-9000	MOLEX

### CN3 : Motor Connector

Item	Specification	Maker
Housing	5557-04R	MOLEX
Terminal	5556T	MOLEX

### CN4 : Power Connector

Item	Specification	Maker
Housing	5557-02R	MOLEX
Terminal	5556T	MOLEX

### CN3 : Motor Connector(86mm motor drive only)

Item	Specification	Maker
Terminal Block	AK950-4	PTR
Housing	3191-4RI	MOLEX
Terminal	138IT	MOLEX

### CN4 : Power Connector(86mm motor drive only)

Item	Specification	Maker
Terminal Block	AK950-2	PTR



## ● System Configuration

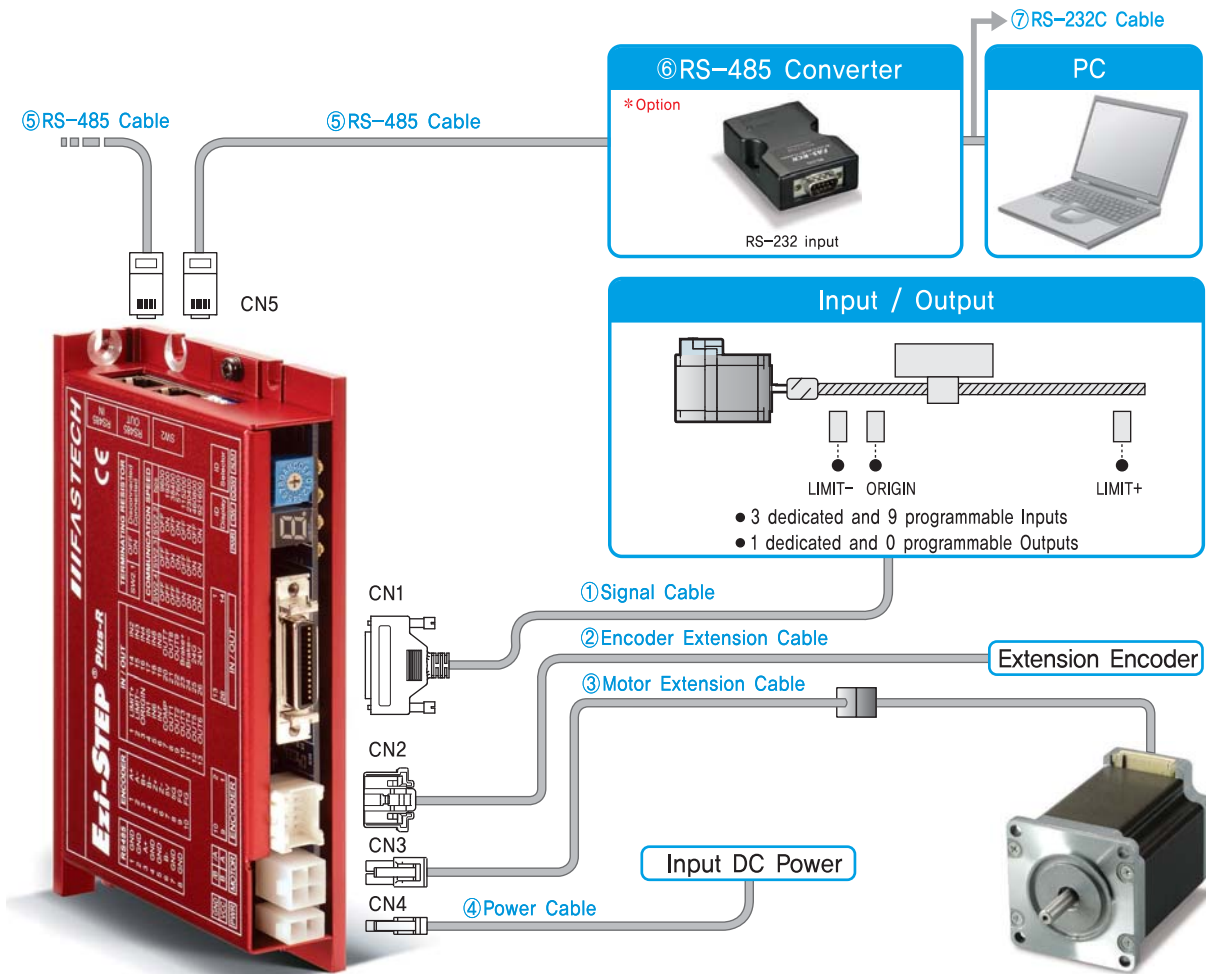

Type	Signal Cable	Encoder Cable	Motor Cable	Power Cable	RS-485 Cable
Standard Length	—	—	30cm	—	—
Max. Length	20m	20m	20m	2m	30m

### 1. Cable Option

#### ① Signal Cable

Available to connect between Control System and Ezi-STEP Plus-R.

Item	Length[m]	Remark
CSVR-S-□□□F	□□□	Normal Cable
CSVR-S-□□□M	□□□	Robot Cable

□ is for Cable Length. The unit is 1m and Max, 20m length.

#### ② Encoder Extension Cable

Available to extended connection between Encoder and Ezi-STEP Plus-R.

Item	Length[m]	Remark
CTPR-E-□□□F	□□□	Normal Cable
CTPR-E-□□□M	□□□	Robot Cable

□ is for Cable Length. The unit is 1m and Max, 20m length.

### ③ Motor Extension Cable

Available to extended connection between motor and Ezi-STEP Plus-R,

Item	Length[m]	Remark
CSVO-M-□□□F	□□□	Normal Cable
CSVO-M-□□□M	□□□	Robot Cable

□ is for Cable Length, The unit is 1m and Max, 20m length.

### ④ Power Cable

Available to connect between Power and Ezi-STEP Plus-R,

Item	Length[m]	Remark
CSVO-P-□□□F	□□□	Normal Cable
CSVO-P-□□□M	□□□	Robot Cable

□ is for Cable Length, The unit is 1m and Max, 2m length.

### ⑤ RS-485 Cable

Item	Length[m]	Remark
CGNR-R-0R6F	0,6	Normal Cable
CGNR-R-001F	1	
CGNR-R-1R5F	1,5	
CGNR-R-002F	2	
CGNR-R-003F	3	
CGNR-R-005F	5	

## 2. Option

### ⑥ FAS-RCR(RS-232C to RS-485 Converter)

Item	Specification
Comm. Speed	Max, 115,2Kbps
Comm. Distance	RS-232C : Max, 15m RS-485 : Max, 1,2km
Connector Type	RS-232C : DB9 Female RS-485 : RJ-45
Operating System	Windows 98/2000/XP/Vista
Dimension	50X75X23mm
Weight	38g
Power	Powered from PC (Usable for external DC5~24V)

### ⑧ TB-Plus(Interface Board)

Available to connect more conveniently between Input/Output signal and Ezi-STEP Plus-R,

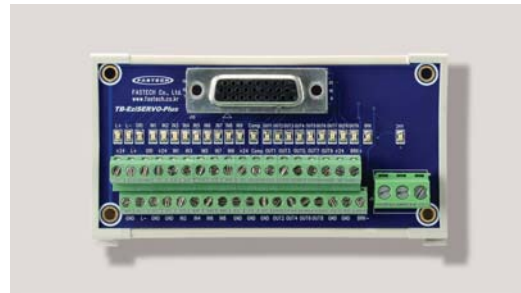

### Interface Cable

Available to Connect between TB-Plus Interface Board and Ezi-STEP Plus-R,

### ⑦ RS-232C Cable

Item	Length[m]	Remark
CGNR-C-1R8F	1,8	Normal Cable
CGNR-C-003F	3	
CGNR-C-005F	5	

Item	Length[m]	Remark
CIFD-S-□□□F	□□□	Normal Cable
CIFD-S-□□□M	□□□	Robot Cable

□ is for Cable Length, The unit is 1m and Max, 20m length.

● System Configuration [Only for 86mm motor drive (EzT-NDR-86 series)]

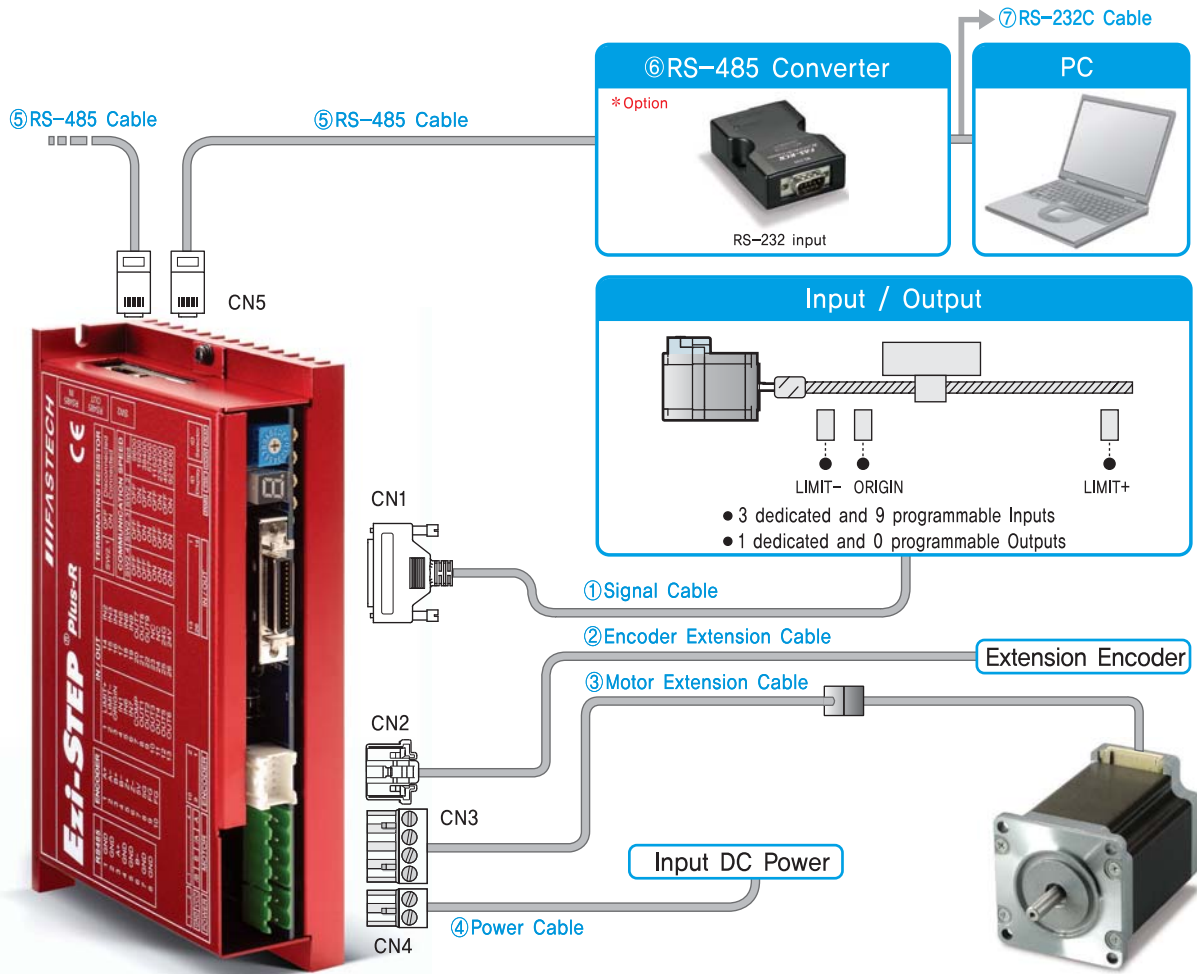

Type	Signal Cable	Encoder Cable	Motor Cable	Power Cable	RS-485 Cable
Standard Length	—	—	30cm	—	—
Max. Length	20m	20m	20m	2m	30m

## 1. Cable Option

### ①Signal Cable

Available to connect between Control System and EzT-NDR-86 Plus-R.

Item	Length[m]	Remark
CSVR-S-□□□F	□□□	Normal Cable
CSVR-S-□□□M	□□□	Robot Cable

□ is for Cable Length. The unit is 1m and Max. 20m length.

### ②Encoder Extension Cable

Available to extended connection between Encoder and EzT-NDR-86 Plus-R.

Item	Length[m]	Remark
CTPR-E-□□□F	□□□	Normal Cable
CTPR-E-□□□M	□□□	Robot Cable

□ is for Cable Length. The unit is 1m and Max. 20m length.

### ③ Motor Extension Cable

Available to extended connection between motor and Ezi-STEP Plus-R.

Item	Length[m]	Remark
CSVP-M-□□□F	□□□	Normal Cable
CSVP-M-□□□M	□□□	Robot Cable

□ is for Cable Length. The unit is 1m and Max, 20m length.

### ④ Power Cable

Available to connect between Power and Ezi-STEP Plus-R.

Item	Length[m]	Remark
CSVP-P-□□□F	□□□	Normal Cable
CSVP-P-□□□M	□□□	Robot Cable

□ is for Cable Length. The unit is 1m and Max, 2m length.

### ⑤ RS-485 Cable

Item	Length[m]	Remark
CGNR-R-0R6F	0.6	Normal Cable
CGNR-R-001F	1	
CGNR-R-1R5F	1.5	
CGNR-R-002F	2	
CGNR-R-003F	3	
CGNR-R-005F	5	

## 2. Option

### ⑥ FAS-RCR(RS-232C to RS-485 Converter)

Item	Specification
Comm. Speed	Max, 115,2Kbps
Comm. Distance	RS-232C : Max, 15m RS-485 : Max, 1,2km
Connector Type	RS-232C : DB9 Female RS-485 : RJ-45
Operating System	Windows 98/2000/XP/Vista
Dimension	50X75X23mm
Weight	38g
Power	Powered from PC (Usable for external DC5~24V)

### ⑧ TB-Plus(Interface Board)

Available to connect more conveniently between Input/Output signal and Ezi-STEP Plus-R.

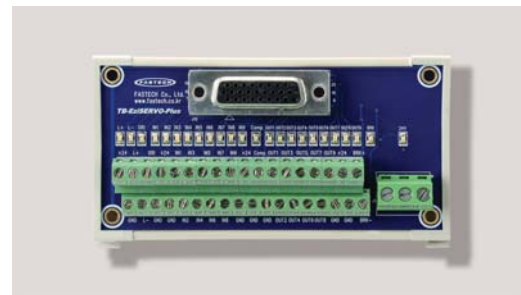

### Interface Cable

Available to Connect between TB-Plus Interface Board and Ezi-STEP Plus-R.

Item	Length[m]	Remark
CIFD-S-□□□F	□□□	Normal Cable
CIFD-S-□□□M	□□□	Robot Cable

□ is for Cable Length. The unit is 1m and Max, 20m length.

### ⑦ RS-232C Cable

Item	Length[m]	Remark
CGNR-C-1R8F	1.8	Normal Cable
CGNR-C-003F	3	
CGNR-C-005F	5	



## External Wiring Diagram

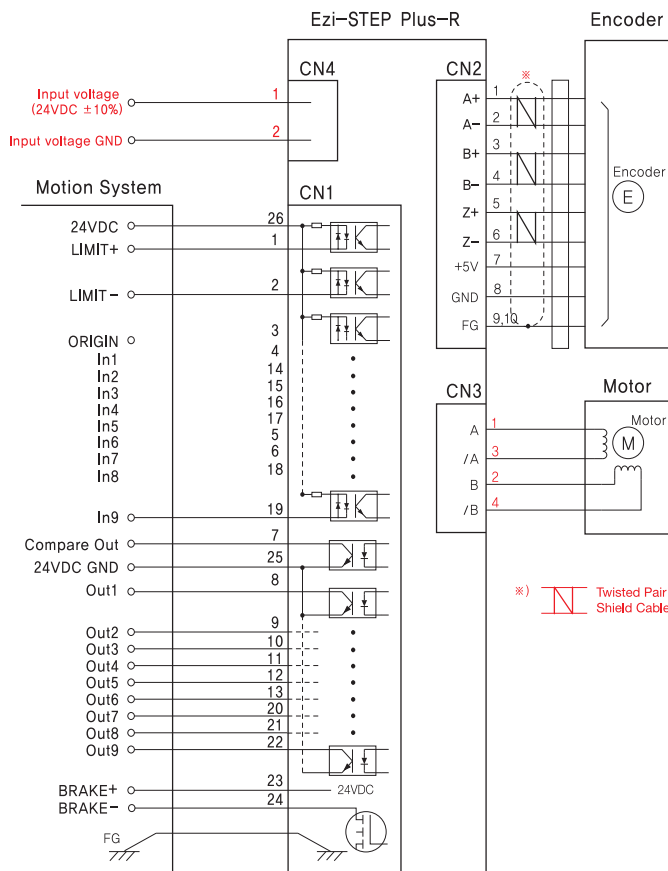

**※ CAUTION ※**  
 Please refer to the Manual when connects motor extension cable. Careful connection will be required to protect any damages.

## External Wiring Diagram [Only for 86mm motor drive (EzT-NDR-86 series)]

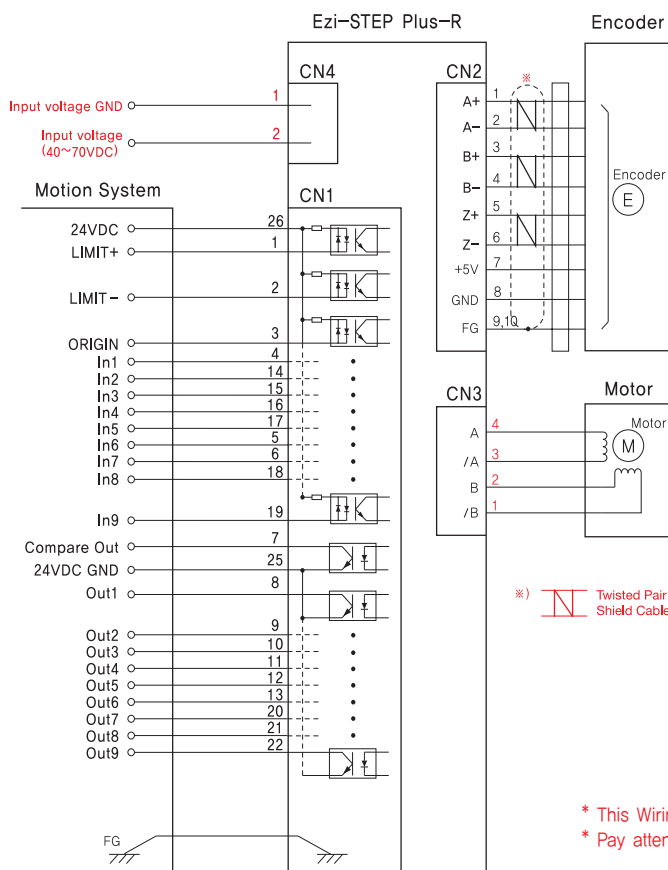

**※ CAUTION ※**  
 Please refer to the Manual when connects motor extension cable. Careful connection will be required to protect any damages.

\* This Wiring Diagram is only for 86mm motor drive (EzT-NDR-86 series).  
 \* Pay attention to red color that describe the difference.

# GUI(Graphic User Interface) Screenshot

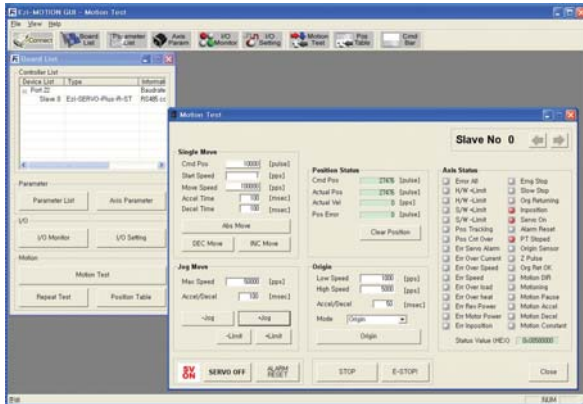

## ◆ Controller Lists and Motion Test

This screen display the controller list that connected to system, You can make a single move, jog and origin command and also the motor status is displayed.

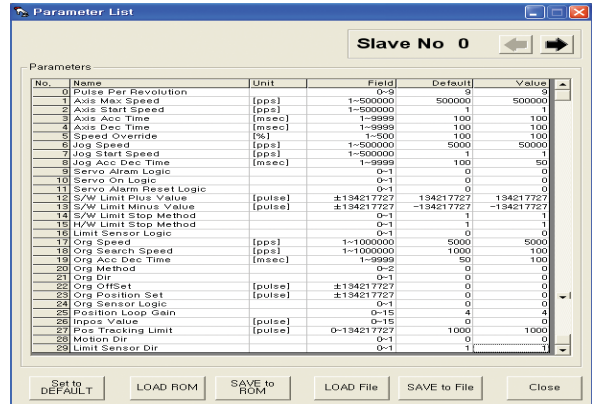

## ◆ Parameter List

All of the parameters are displayed and modified on this screen.

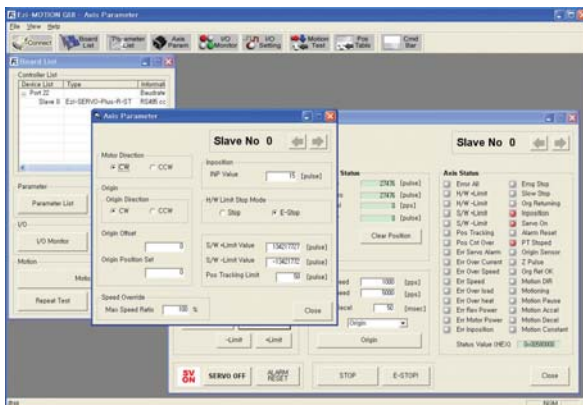

## ◆ Axis Parameter Setup

You can select various parameters that frequently used, (ex : sensor input logic)

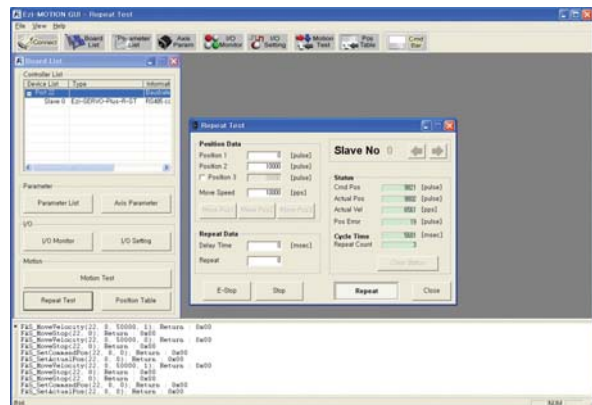

## ◆ Motion Repeat and Monitor Status

Target position, speed, delay time and repeat count are selected for repeat motion test. Motion library(DLL) is also displayed on screen.

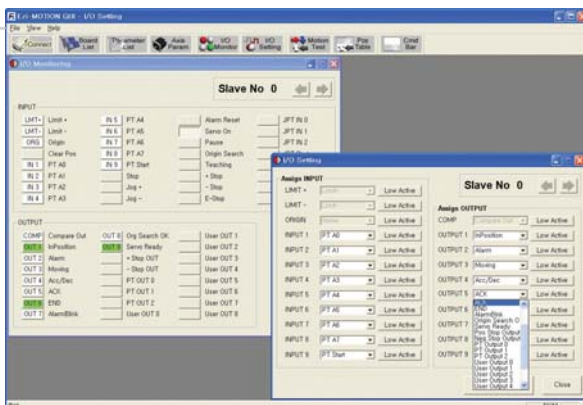

## ◆ I/O Monitoring and Setting

You can select various digital input and output signals of controller,

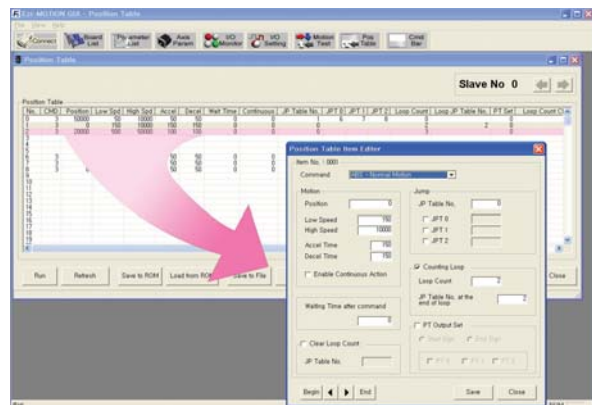

## ◆ Position Table

You can edit the position table and execute it. The position table data can be saved and loaded from Flash ROM and Windows file.

MEMO

FASTECH Ezi-STEP Plus-R



**FASTECH Co., Ltd.**

Rm #1202, Bucheon Technopark 401 Dong, Yakdea-dong,  
Wonmi-Gu, Bucheon-si, Gyeonggi-do, Rep. Of Korea (Zip)420-734  
TEL : 82-32-234-6300,6301 FAX : 82-32-234-6302  
E-mail : daniel@fastech.co.kr website: www.fastech.co.kr

**FASTECH AMERICA LLC**

811 E Plano Parkway, Suite 110A, Plano, TX 75074 USA  
Toll Free: 877-905-4428 972-218-0210  
Email: support@fastechamerica.com  
website: www.fastechamerica.com