

# **Ezi-SERVO<sup>®</sup>**

## **Closed Loop Stepping Systems**

# **ST**



[www.fastech.co.kr](http://www.fastech.co.kr)

## Table of Contents

<b>1. Precautions</b>	1
<b>2. Main characteristics</b>	5
<b>3. Drive Specification and Dimension</b>	8
3.1 Drive Specification	8
3.2 Drive Dimension	9
<b>4. Motor Specification and Size</b>	10
4.1 EzM-20 Series	10
4.2 EzM-25 Series	11
4.3 EzM-28 Series	12
4.4 EzM-35 Series	13
4.5 EzM-42 Series	14
4.6 EzM-56 Series	15
4.7 EzM-60 Series	17
4.8 EzM-71 Series	18
4.9 EzM-86 Series	19
<b>5. Installation and Cabling</b>	20
5.1 Notes on Installation	23
5.2 Connection Diagram	23
<b>6. Setting and Operating</b>	24
6.1 Operation Monitor Status from LEDs	25
6.2 Pulse input selection switch(SW1,1)	26
6.3 Rotational direction selection switch(SW1,2)	27
6.4 Position Controller Gain select switch(SW2)	27
6.5 Resolution set switch(SW3)	28
6.6 In-Position value set switch(SW4)	28
6.7 Motor Connector(CN3)	29
6.8 Power Connector(CN4)	30
6.9 Control signal Input/Output Connector(CN1)	30
6.10 Encoder Connector(CN2)	31
6.11 Run Current	31
<b>7. System Configuration</b>	31
7.1 Option	32
<b>8. System Configuration [86mm motor drive only(EzS-PD-86 series)]</b>	32
8.1 Option	33
<b>9. Control Signal Input/Output Description</b>	34
9.1 Input signal	34
9.2 Output signal	35
<b>Appendix</b>	36
Extension cable for Motor	36
Extension cable for Encoder	37
Connector	38

## ※ Before operation ※

- Thank you for your purchasing Ezi-SERVO.
- Ezi-SERVO is an all-in-one Unit. For high-speed and high-precision drive of a stepping motor, Ezi-SERVO is a unique drive that adopts a new control scheme owing to an on-board high-performance 32bit digital signal processor.
- This manual describes handling, maintenance, repair, diagnosis and troubleshooting of Ezi-SERVO.
- Before operating Ezi-SERVO, thoroughly read this manual.
- After reading the manual, keep the manual near the Ezi-SERVO so that any user can read the manual whenever needed.

## 1. Precautions

### ◆ General Precautions

- Contents of this manual are subject to change without prior notice for functional improvement, change of specifications or user's better understanding. Thoroughly read the manual provided with the purchased Ezi-STEP.
- When the manual is damaged or lost, please contact with Fastech's agents or our company at the address on the last page of the manual.
- Our company is not responsible for a product breakdown due to user's dismantling for the product, and such a breakdown is not guaranteed by the warranty.

### ◆ Put the Safety First

- Before installation, operation and repairing the Ezi-STEP, thoroughly read the manual and fully understand the contents. Before operating the Ezi-STEP please, understand the mechanical characteristics of the Ezi-STEP and related safety information and precautions.
- This manual divides safety precautions into **Attention** and **Warning**.

 **Attention** : If user does not properly handle the product, the user may seriously or slightly injured and damages may occur in the machine.



 **Warning** : If user does not properly handle the product, a dangerous situation (such as an electric shock) may occur resulting in deaths or serious injuries.

- Although precaution is only a **Attention**, a serious result could be caused depending on the situation. Follow safety precautions.



## ◆ Check the Product

 <b>Attention</b>	<p>Check the Product is damaged or parts are missing. Otherwise, the machine may get damaged or the user may get injured.</p>
--	---

## ◆ Installation

 <b>Attention</b>	<p>Carefully move the Ezi-SERVO. Otherwise the Product may get damaged or User's foot may get injured by dropping the product.</p> <p>Use non-flammable materials such as metal in the place where the Ezi-SERVO is to be installed. Otherwise, a fire may occur.</p> <p>When installing several Ezi-SERVO in a sealed place, install a cooling fan to keep the ambient temperature of the Ezi-SERVO as 50°C or lower. Otherwise, a fire or other kinds of accidents may occur due to overheating.</p>
 <b>Warning</b>	<p>The process of Installation, Connection, Operation, Checking and Repairing should be done with qualified person. Otherwise, a fire or other kinds of accidents may occur.</p>

## ◆ Connect Cables

 <b>Attention</b>	<p>Keep the rated range of Input Voltage for Ezi-SERVO. Otherwise, a fire or other kinds of accidents may occur.</p> <p>Cable connection should follow the wiring diagram. Otherwise, a fire or other kinds of accidents may occur.</p>
 <b>Warning</b>	<p>Before connecting cables, check if input power is off. Otherwise, an electric shock or a fire may occur.</p> <p>The case of the Ezi-SERVO is insulated from the ground of the internal circuit by the condenser. Ground the Ezi-SERVO. Otherwise, an electric shock or a fire may occur.</p>

## ◆ Operation



### Attention

If a protection function(alarm) occurs, firstly remove its cause and then release(alarm reset) the protection function.

If you operate continuously without removing its cause, the machine may get damaged or the user may get injured.

**Do not make Motor Free and make input signal to ON during operation.**

Motor will stop and stop current will become zero. The machine may get damaged or the user may get injured.

**Make all input signals to OFF before supply input voltage to Ezi-SERVO.**

The machine may get damaged or the user may get injured by motor operation.

**All parameter values are set by default factory setting value. Change this value after reading this manual thoroughly.**

Otherwise, the machine may get damaged or other kinds of accidents may occur.

## ◆ Check and Repair



### Warning

**Stop to supply power to the main circuit and wait for a while before checking or repairing the Ezi-SERVO.**

Electricity remaining in the capacitor may cause danger.

**Do not change cabling while power is being supplied.**

Otherwise, the user may get injured or the product may get damaged.

**Do not reconstruct the Ezi-SERVO.**

Otherwise, an electric shock may occur or the reconstructed product can not get After-Service.

## ■ Part Numbering

### Ezi-SERVO-42S-A-□

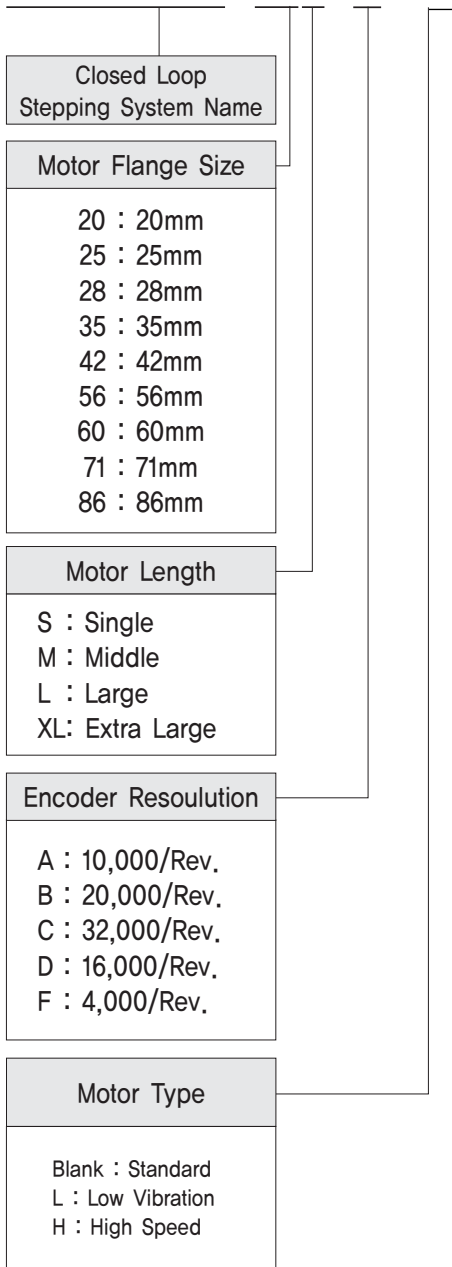

## ■ Combination List of Ezi-SERVO

Unit Part Number	Motor Model Number	Drive Model Number
Ezi-SERVO-20M-F	EzM-20M-F	EzS-PD-20M-F
Ezi-SERVO-20L-F	EzM-20L-F	EzS-PD-20L-F
Ezi-SERVO-25S-F-L	EzM-25S-F-L	EzS-PD-25S-F-L
Ezi-SERVO-25M-F-L	EzM-25M-F-L	EzS-PD-25M-F-L
Ezi-SERVO-25L-F-L	EzM-25L-F-L	EzS-PD-25L-F-L
Ezi-SERVO-28S-D	EzM-28S-D	EzS-PD-28S-D
Ezi-SERVO-28M-D	EzM-28M-D	EzS-PD-28M-D
Ezi-SERVO-28L-D	EzM-28L-D	EzS-PD-28L-D
Ezi-SERVO-35S-D	EzM-35S-D	EzS-PD-35S-D
Ezi-SERVO-35M-D	EzM-35M-D	EzS-PD-35M-D
Ezi-SERVO-35L-D	EzM-35L-D	EzS-PD-35L-D
Ezi-SERVO-35XL-D	EzM-35XL-D	EzS-PD-35XL-D
Ezi-SERVO-42S-A	EzM-42S-A	EzS-PD-42S-A
Ezi-SERVO-42S-B	EzM-42S-B	EzS-PD-42S-B
Ezi-SERVO-42S-C	EzM-42S-C	EzS-PD-42S-C
Ezi-SERVO-42M-A	EzM-42M-A	EzS-PD-42M-A
Ezi-SERVO-42M-B	EzM-42M-B	EzS-PD-42M-B
Ezi-SERVO-42M-C	EzM-42M-C	EzS-PD-42M-C
Ezi-SERVO-42L-A	EzM-42L-A	EzS-PD-42L-A
Ezi-SERVO-42L-B	EzM-42L-B	EzS-PD-42L-B
Ezi-SERVO-42L-C	EzM-42L-C	EzS-PD-42L-C
Ezi-SERVO-42XL-A	EzM-42XL-A	EzS-PD-42XL-A
Ezi-SERVO-42XL-B	EzM-42XL-B	EzS-PD-42XL-B
Ezi-SERVO-42XL-C	EzM-42XL-C	EzS-PD-42XL-C
Ezi-SERVO-56S-A	EzM-56S-A	EzS-PD-56S-A
Ezi-SERVO-56S-B	EzM-56S-B	EzS-PD-56S-B
Ezi-SERVO-56S-C	EzM-56S-C	EzS-PD-56S-C
Ezi-SERVO-56M-A	EzM-56M-A	EzS-PD-56M-A
Ezi-SERVO-56M-B	EzM-56M-B	EzS-PD-56M-B
Ezi-SERVO-56M-C	EzM-56M-C	EzS-PD-56M-C
Ezi-SERVO-56L-A	EzM-56L-A	EzS-PD-56L-A
Ezi-SERVO-56L-B	EzM-56L-B	EzS-PD-56L-B
Ezi-SERVO-56L-C	EzM-56L-C	EzS-PD-56L-C
Ezi-SERVO-56S-A-L	EzM-56S-A-L	EzS-PD-56S-A-L
Ezi-SERVO-56S-B-L	EzM-56S-B-L	EzS-PD-56S-B-L
Ezi-SERVO-56S-C-L	EzM-56S-C-L	EzS-PD-56S-C-L
Ezi-SERVO-56M-A-L	EzM-56M-A-L	EzS-PD-56M-A-L
Ezi-SERVO-56M-B-L	EzM-56M-B-L	EzS-PD-56M-B-L
Ezi-SERVO-56M-C-L	EzM-56M-C-L	EzS-PD-56M-C-L
Ezi-SERVO-56L-A-L	EzM-56L-A-L	EzS-PD-56L-A-L
Ezi-SERVO-56L-B-L	EzM-56L-B-L	EzS-PD-56L-B-L
Ezi-SERVO-56L-C-L	EzM-56L-C-L	EzS-PD-56L-C-L
Ezi-SERVO-60S-A	EzM-60S-A	EzS-PD-60S-A
Ezi-SERVO-60S-B	EzM-60S-B	EzS-PD-60S-B
Ezi-SERVO-60S-C	EzM-60S-C	EzS-PD-60S-C
Ezi-SERVO-60M-A	EzM-60M-A	EzS-PD-60M-A
Ezi-SERVO-60M-B	EzM-60M-B	EzS-PD-60M-B
Ezi-SERVO-60M-C	EzM-60M-C	EzS-PD-60M-C
Ezi-SERVO-60L-A	EzM-60L-A	EzS-PD-60L-A
Ezi-SERVO-60L-B	EzM-60L-B	EzS-PD-60L-B
Ezi-SERVO-60L-C	EzM-60L-C	EzS-PD-60L-C
Ezi-SERVO-71M-A-L	EzM-71M-A-L	EzS-PD-71M-A-L
Ezi-SERVO-71M-B-L	EzM-71M-B-L	EzS-PD-71M-B-L
Ezi-SERVO-71M-C-L	EzM-71M-C-L	EzS-PD-71M-C-L
Ezi-SERVO-71L-A-L	EzM-71L-A-L	EzS-PD-71L-A-L
Ezi-SERVO-71L-B-L	EzM-71L-B-L	EzS-PD-71L-B-L
Ezi-SERVO-71L-C-L	EzM-71L-C-L	EzS-PD-71L-C-L
Ezi-SERVO-86M-A	EzM-86M-A	EzS-PD-86M-A
Ezi-SERVO-86M-B	EzM-86M-B	EzS-PD-86M-B
Ezi-SERVO-86M-C	EzM-86M-C	EzS-PD-86M-C
Ezi-SERVO-86L-A	EzM-86L-A	EzS-PD-86L-A
Ezi-SERVO-86L-B	EzM-86L-B	EzS-PD-86L-B
Ezi-SERVO-86L-C	EzM-86L-C	EzS-PD-86L-C
Ezi-SERVO-86XL-A	EzM-86XL-A	EzS-PD-86XL-A
Ezi-SERVO-86XL-B	EzM-86XL-B	EzS-PD-86XL-B
Ezi-SERVO-86XL-C	EzM-86XL-C	EzS-PD-86XL-C

## 2. Main characteristics

### 1 Closed Loop System.

Ezi-SERVO<sup>2</sup> is an innovative closed loop stepping motor and controller that utilizes a high-resolution motor mounted encoder to constantly monitor the motor shaft position. The encoder feedback feature allows the Ezi-SERVO<sup>2</sup> to update the current motor shaft position information every 25 micro seconds. This allows the Ezi-SERVO<sup>2</sup> drive to compensate for the loss of position, ensuring accurate positioning. For example, due to a sudden load change, a conventional stepper motor and drive could lose a step creating a positioning error and a great deal of cost to the end user!

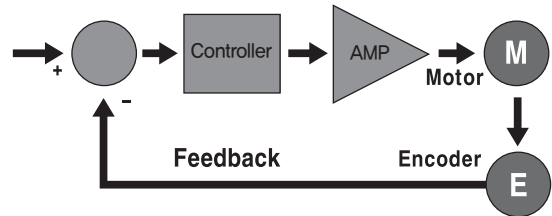

### 2 No Gain Tuning

Conventional servo systems, to ensure machine performance, smoothness, positional error and low servo noise, require the adjustment of its servo's gains as an initial crucial step. Even systems that employ auto-tuning require manual tweaking after the system is installed, especially if more than one axis are interdependent. Ezi-SERVO<sup>2</sup> employs the best characteristics of stepper and closed loop motion controls and algorithms to eliminate the need of tedious gain tuning required for conventional closed loop servo systems. This means that Ezi-SERVO<sup>2</sup> is optimized for the application and ready to work right out of the box! The Ezi-SERVO<sup>2</sup> system employs the unique characteristics of the closed loop stepping motor control, eliminating these cumbersome steps and giving the engineer a high performance servo system without wasting setup time. Ezi-SERVO<sup>2</sup> is especially well suited for low stiffness loads (for example, a belt and pulley system) that some-time require conventional servo systems to inertia match with the added expense and bulk of a gearbox. Ezi-SERVO<sup>2</sup> also performs exceptionally, even under heavy loads and high speeds!

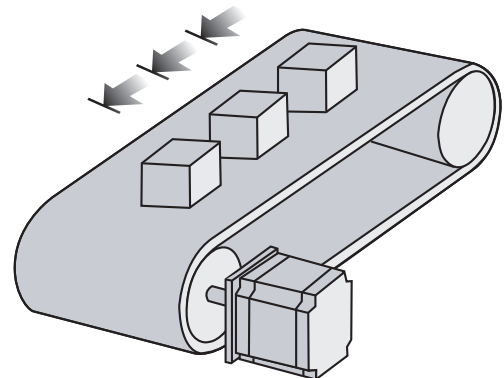

Belt and Pulley System

### 3 No Hunting

Traditional servo motor drives overshoot their position and try to correct by overshooting the opposite direction, especially in high gain applications. This is called null hunt and is especially prevalent in systems that the break away or static friction is significantly higher than the running friction. The cure is lowering the gain, which affects accuracy or using Ezi-SERVO<sup>2</sup> Motion Control System! Ezi-SERVO<sup>2</sup> utilizes the unique characteristics of stepping motors and locks itself into the desired target position, eliminating Null Hunt. This feature is especially useful in applications such as nanotech manufacturing, semiconductor fabrication, vision systems and ink jet printing in which system oscillation and vibration could be a problem.

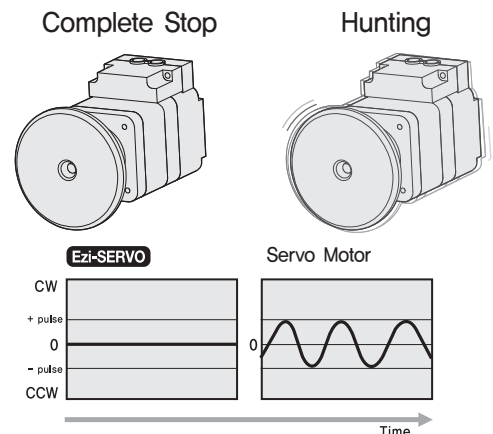

## 4 Smooth and Accurate

Ezi-SERVO<sup>®</sup> is a high-precision servo drive, using a high-resolution encoder with 32,000 pulses/revolution.

Unlike a conventional Microstep drive, the on-board high performance DSP(Digital Signal Processor) performs vector control and filtering, producing a smooth rotational control with minimum ripples.

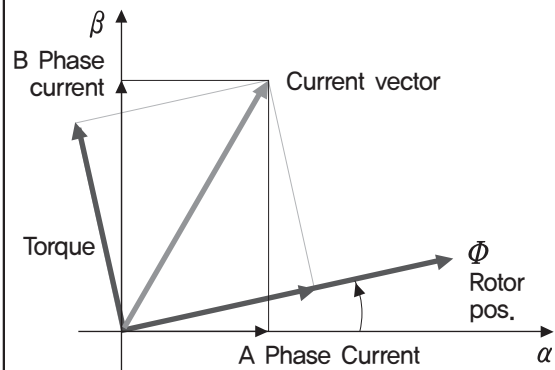

## 5 Fast Response

Similar to conventional stepping motors, Ezi-SERVO<sup>®</sup> instantly synchronizes with command pulses providing fast positional response.

Ezi-SERVO<sup>®</sup> is the optimum choice when zero-speed stability and rapid motions within a short distance are required. Traditional servo motor systems have a natural delay between the commanding input signals and the resultant motion because of the constant monitoring of the current position, necessitating in a waiting time until it settles, called settling time.

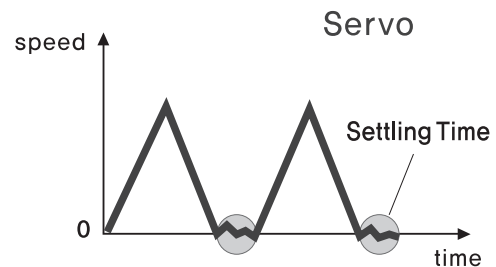
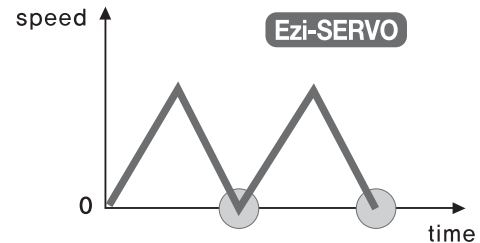

## 6 High Resolution

The unit of the position command can be divided precisely.  
(Max. 32,000 pulses/revolution)

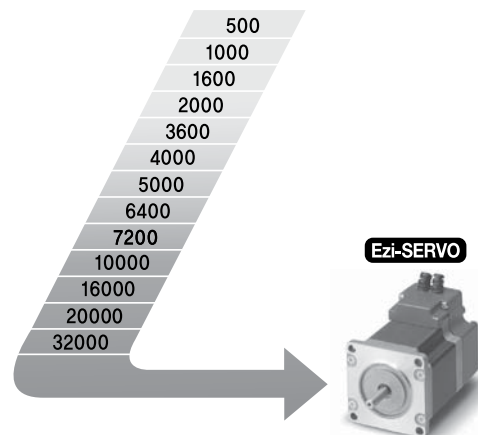



## 7 High Torque

Compared with common step motors and drives, Ezi-SERVO<sup>®</sup> motion control systems can maintain a high torque state over relatively long period of time. This means that Ezi-SERVO continuously operates without loss of position under 100% of the load. Unlike conventional microstep drives, Ezi-SERVO<sup>®</sup> exploits continuous high-torque operation during high-speed motion due to its innovative optimum current phase control.

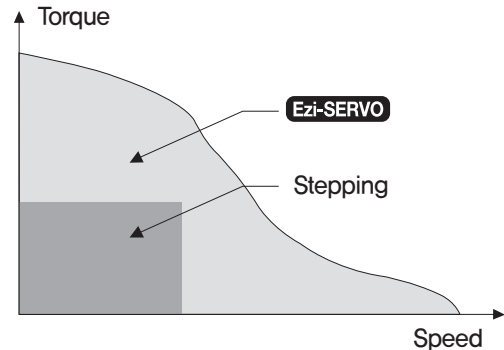

## 8 High Speed

The Ezi-SERVO<sup>®</sup> functions well at high speed without the loss of Synchronism or positioning error. Ezi-SERVO's ability of continuous monitoring of current position enables the stepping motor to generate high-torque, even under a 100% load condition.

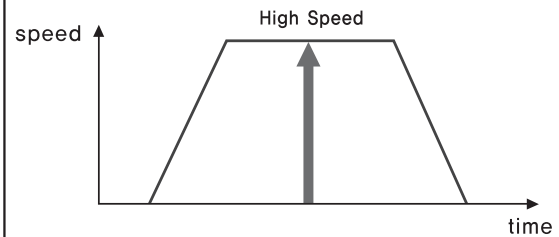

## 9 Load-Dependent Current Control

Since the drive controls the operating current depending on the variation of a load, it reduces the heat generation, improving efficiency.

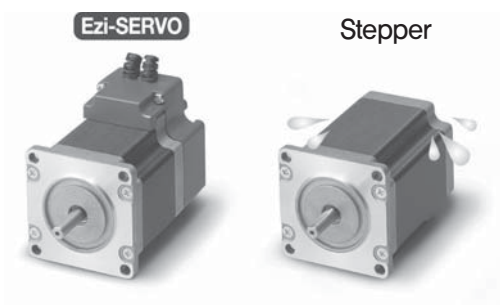

## 3. Drive Specification and Dimension

### 3.1 Drive specification

Motor Model	EzM-20 series	EzM-25 series	EzM-28 series	EzM-35 series	EzM-42 series	EzM-56 series	EzM-60 series	EzM-71 series	EzM-86 series
Driver Model	EzS-PD-20 series	EzS-PD-25 series	EzS-PD-28 series	EzS-PD-35 series	EzS-PD-42 series	EzS-PD-56 series	EzS-PD-60 series	EzS-PD-71 series	EzS-PD-86 series
Input Voltage	24VDC $\pm$ 10%								40~70VDC
Control Method	Closed loop control with 32bit DSP								
Current Consumption	Max 500mA (Except motor current)								
Operating Condition	Ambient Temperature	In Use : 0~50°C In Storage : -20~70°C							
	Humidity	In Use : 35~85% (Non-Condensing) In Storage : 10~90% (Non-Condensing)							
	Vib. Resist.	0.5G							
Function	Rotation Speed	0~3000rpm							
	Resolution(P/R)	4,000/Rev. Encoder model : 500 1,000 1,600 2,000 3,600 5,000 6,400 7,200 10,000 4,000 10,000/Rev. Encoder model : 500 1,000 1,600 2,000 3,600 5,000 6,400 7,200 10,000 16,000/Rev. Encoder model : 500 1,000 1,600 2,000 3,600 5,000 6,400 7,200 10,000 16,000 20,000/Rev. Encoder model : 500 1,000 1,600 2,000 3,600 5,000 6,400 7,200 10,000 20,000 32,000/Rev. Encoder model : 500 1,000 1,600 2,000 3,600 5,000 6,400 7,200 10,000 32,000 (Selectable with Rotary switch)							
	Max. Input Pulse Frequency	500KHz (Duty 50%)							
	Protection Functions	Over current, Over speed, Position tracking error, Over load, Over temperature, Over regenerated voltage, Motor connect error, Encoder connect error, Motor voltage error, In-Position error, System error, ROM error, Input voltage error, Position overflow error							
	LED Display	Power status, Alarm status, In-Position status, Servo On status							
	In-Position Selection	0~F (Selectable with Rotary switch)							
	Position Gain Selection	0~F (Selectable with Rotary switch)							
	Pulse Input Method	1-Pulse / 2-Pulse (Selectable with DIP switch)							
	Rotational Direction	CW / CCW (Selectable with DIP switch)							
	Speed/Position Control Command	Pulse train input							
I/O Signal	Input Signals	Position command pulse, Servo On/Off, Alarm reset (Photocoupler input)							
	Output Signals	In-Position, Alarm (Photocoupler output) Encoder signal (A+, A-, B+, B-, Z+, Z-, 26C31 of Equivalent) (Line Driver output)							

### 3.2 Drive dimension(mm)

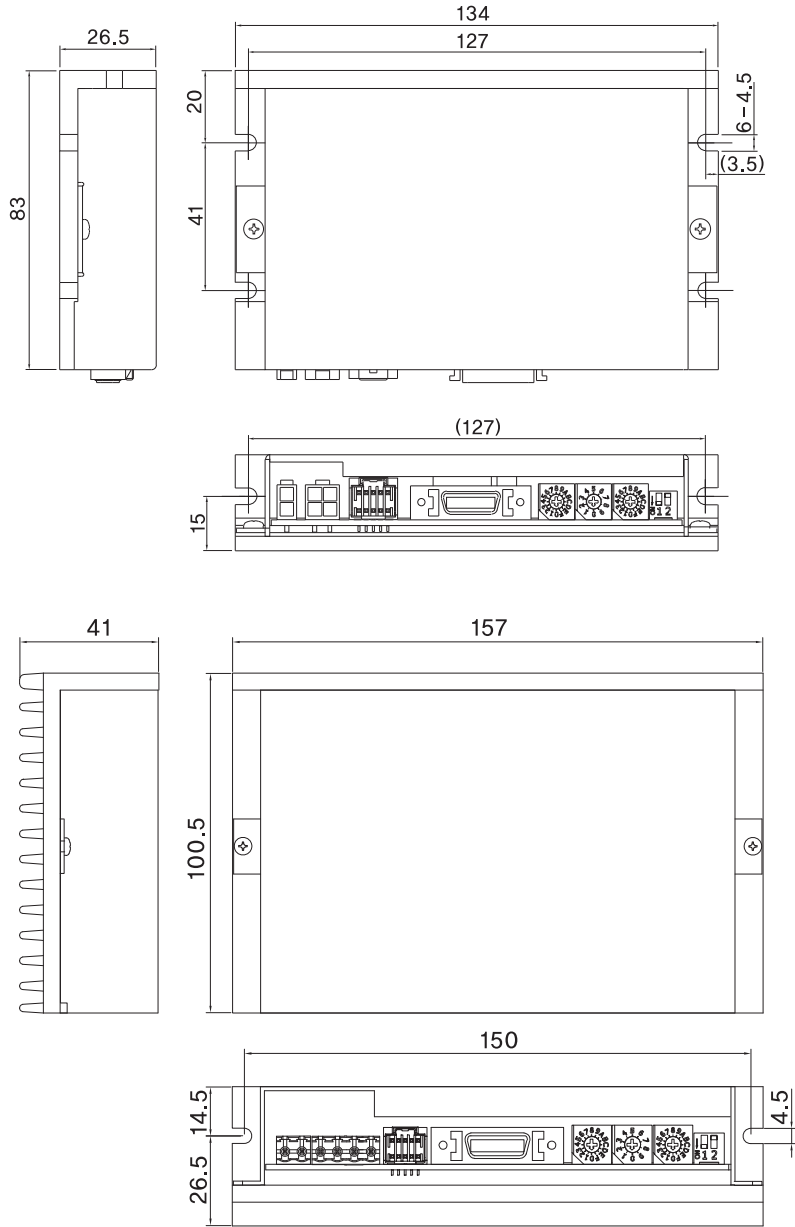

※Only for 86mm motor drive(EzS-PD-86 Series)

## 4. Motor specifications and Size

### 4.1 EzM-20 Series

#### 4.1.1 Motor Specifications

M O D E L		UNIT	EzM-20M-F	EzM-20L-F
DRIVE METHOD		----	BI-POLAR	BI-POLAR
NUMBER OF PHASES		----	2	2
VOLTAGE		VDC	2,9	2,25
CURRENT per PHASE		A	0,5	0,5
RESISTANCE per PHASE		Ohm	5,8	5,5
INDUCTANCE per PHASE		mH	2,5	5
HOLDING TORQUE		N · m	0,018	0,03
ROTOR INERTIA		g · cm <sup>2</sup>	2,5	3,3
WEIGHTS		g	50	80
LENGTH (L)		mm	28	38
ALLOWABLE OVERHUNG LOAD (DISTANCE FROM END OF SHAFT)	3mm	N	18	18
	8mm		30	30
ALLOWABLE THRUST LOAD		N	Lower than motor weight	
INSULATION RESISTANCE		MOhm	100min. (at 500VDC)	
INSULATION CLASS		----	CLASS B (130°C)	
OPERATING TEMPERATURE		°C	0 to 55	

#### 4.1.2 Motor Dimension (mm)

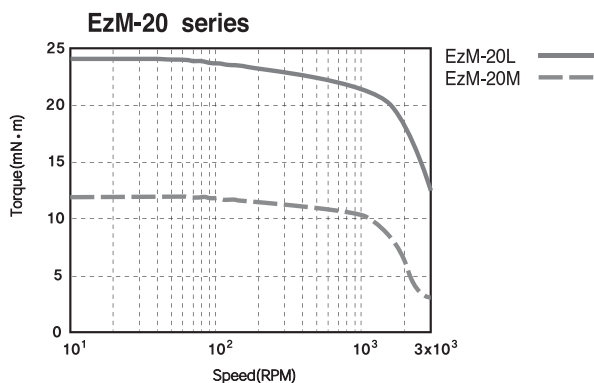
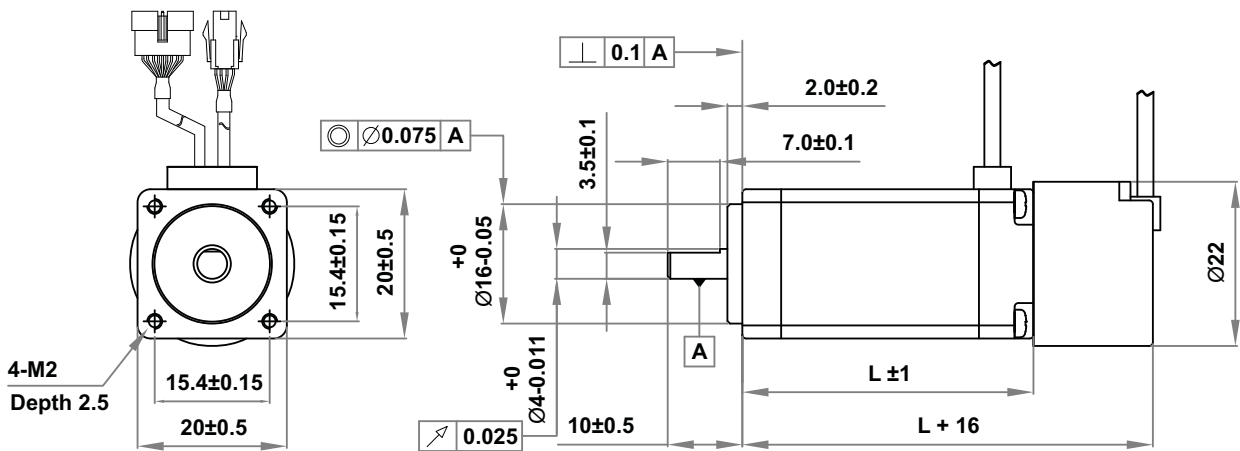

※ Measured Condition

Motor Voltage = 24VDC

Motor Current = Rated Current(Refer to Motor Specification)

Drive = Ezi-SERVO

## 4.2 EzM-25 Series

### 4.2.1 Motor Specifications

*Low Vibration*

M O D E L		UNIT	EzM-25S-F-L	EzM-25M-F-L	EzM-25L-F-L
DRIVE METHOD		----	BI-POLAR	BI-POLAR	BI-POLAR
NUMBER OF PHASES		----	2	2	2
VOLTAGE		VDC	2.66	9.87	3.654
CURRENT per PHASE		A	0.7	0.21	0.63
RESISTANCE per PHASE		Ohm	3.8	47	5.8
INDUCTANCE per PHASE		mH	2.0	30	5.4
HOLDING TORQUE		N · m	0.033	0.049	0.062
ROTOR INERTIA		g · cm <sup>2</sup>	2	3	7
WEIGHTS		g	85	100	120
LENGTH (L)		mm	23.5	27.5	33
ALLOWABLE OVERHUNG LOAD (DISTANCE FROM END OF SHAFT)	3mm	N	30	30	30
	8mm		38	38	38
ALLOWABLE THRUST LOAD		N	Lower than motor weight		
INSULATION RESISTANCE		MOhm	100min. (at 500VDC)		
INSULATION CLASS		----	CLASS B (130°C)		
OPERATING TEMPERATURE		°C	0 to 55		

### 4.2.2 Motor Dimension (mm)

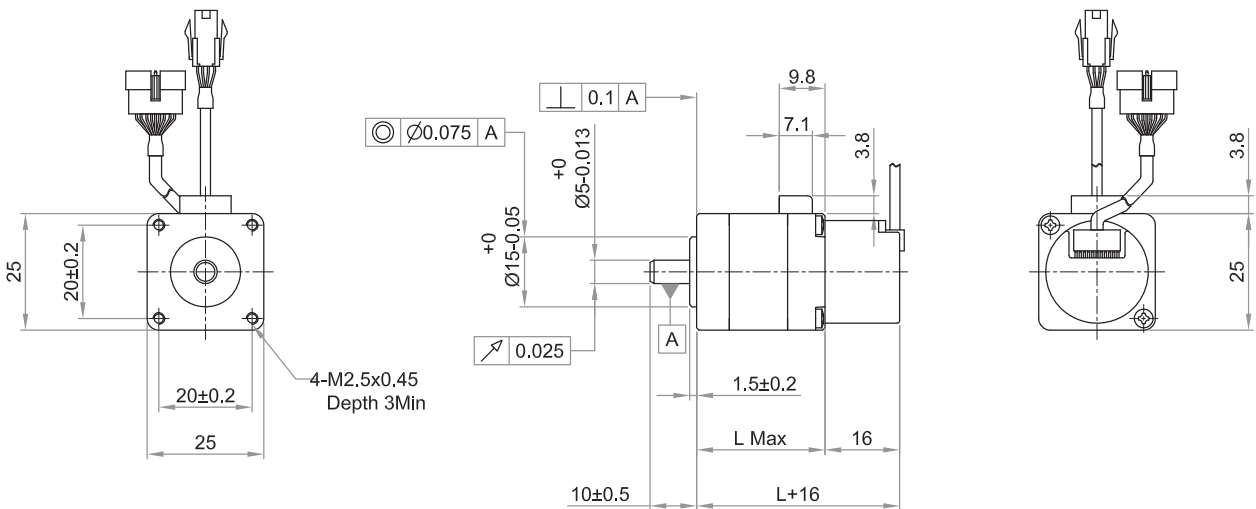

**EzM-25 series**

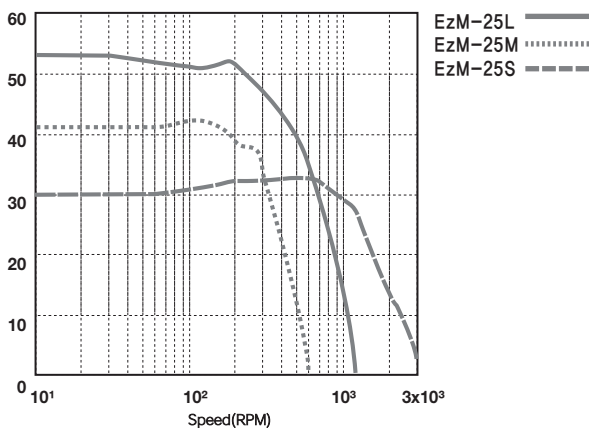

※ Measured Condition

Motor Voltage = 24VDC

Motor Current = Rated Current (Refer to Motor Specification)

Drive = Ezi-SERVO

## 4.3 EzM-28 Series

### 4.3.1 Motor Specifications

M O D E L		UNIT	EzM-28S-D	EzM-28M-D	EzM-28L-D
DRIVE METHOD		----	BI-POLAR	BI-POLAR	BI-POLAR
NUMBER OF PHASES		----	2	2	2
VOLTAGE		VDC	3,04	3,04	3,42
CURRENT per PHASE		A	0,95	0,95	0,95
RESISTANCE per PHASE		Ohm	3,2	3,2	3,6
INDUCTANCE per PHASE		mH	2	5	5,8
HOLDING TORQUE		N · m	0,07	0,12	0,14
ROTOR INERTIA		g · cm <sup>2</sup>	9	13	18
WEIGHTS		g	110	140	200
LENGTH (L)		mm	32	45	52
ALLOWABLE OVERHUNG LOAD (DISTANCE FROM END OF SHAFT)	3mm	N	30	30	30
	8mm		38	38	38
	13mm		53	53	53
	18mm		84	84	84
ALLOWABLE THRUST LOAD		N	Lower than motor weight		
INSULATION RESISTANCE		MOhm	100min. (at 500VDC)		
INSULATION CLASS		----	CLASS B (130°C)		
OPERATING TEMPERATURE		°C	0 to 55		

### 4.3.2 Motor Dimension (mm) and Torque Characteristics

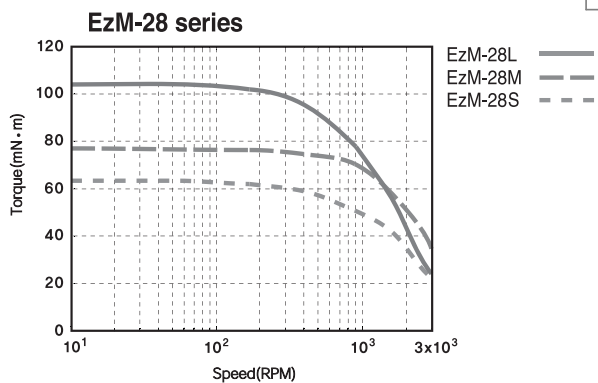
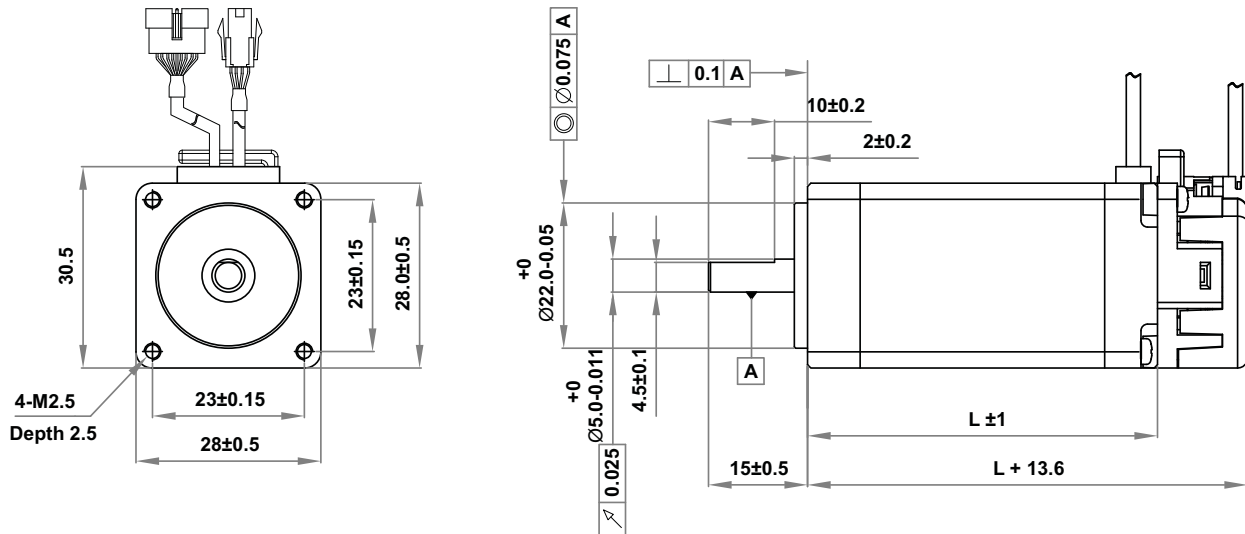

※ Measured Condition

Motor Voltage = 24VDC  
 Motor Current = Rated Current(Refer to Motor Specification)  
 Drive = Ezi-SERVO



## 4.5 EzM-42 Series

### 4.5.1 Motor Specifications

M O D E L	UNIT	EzM-42S-A	EzM-42M-A	EzM-42L-A	EzM-42XL-A	
		EzM-42S-B	EzM-42M-B	EzM-42L-B	EzM-42XL-B	
		EzM-42S-C	EzM-42M-C	EzM-42L-C	EzM-42XL-C	
DRIVE METHOD	----	BI-POLAR	BI-POLAR	BI-POLAR	BI-POLAR	
NUMBER OF PHASES	----	2	2	2	2	
VOLTAGE	VDC	3,36	4,32	4,56	7,2	
CURRENT per PHASE	A	1,2	1,2	1,2	1,2	
RESISTANCE per PHASE	Ohm	2,8	3,6	3,8	6	
INDUCTANCE per PHASE	mH	2,5	7,2	8	15,6	
HOLDING TORQUE	N · m	0,32	0,44	0,54	0,8	
ROTOR INERTIA	g · cm <sup>2</sup>	35	54	77	114	
WEIGHTS	g	220	280	350	500	
LENGTH (L)	mm	33	39	47	59	
ALLOWABLE OVERHUNG LOAD (DISTANCE FROM END OF SHAFT)	3mm	N	22	22	22	22
	8mm		26	26	26	26
	13mm		33	33	33	33
	18mm		46	46	46	46
ALLOWABLE THRUST LOAD	N	Lower than motor weight				
INSULATION RESISTANCE	MOhm	100min. (at 500VDC)				
INSULATION CLASS	----	CLASS B (130°C)				
OPERATING TEMPERATURE	°C	0 to 55				

### 4.5.2 Motor Dimension (mm) and Torque Characteristics

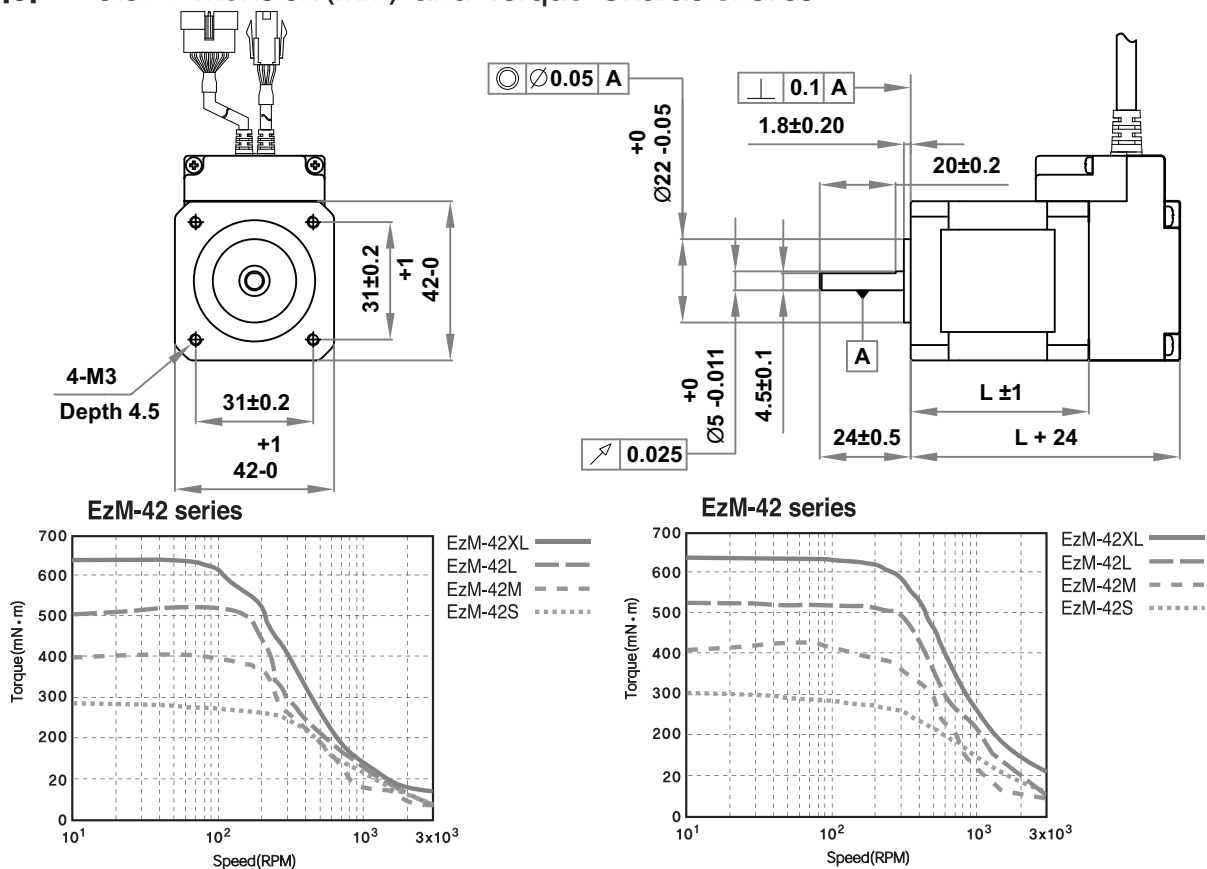

※ Measured Condition

Motor Voltage = 24VDC  
 Motor Current = Rated Current(Refer to Motor Specification)  
 Drive = Ezi-SERVO

※ Measured Condition

Motor Voltage = 40VDC  
 Motor Current = Rated Current(Refer to Motor Specification)  
 Drive = Ezi-SERVO



## 4.6 EzM-56 Series

### 4.6.1 Motor Specifications

MODEL		UNIT	EzM-56S-A EzM-56S-B EzM-56S-C	EzM-56M-A EzM-56M-B EzM-56M-C	EzM-56L-A EzM-56L-B EzM-56L-C
DRIVE METHOD		----	BI-POLAR	BI-POLAR	BI-POLAR
NUMBER OF PHASES		----	2	2	2
VOLTAGE		VDC	1,56	2,1	2,7
CURRENT per PHASE		A	3	3	3
RESISTANCE per PHASE		Ohm	0,52	0,7	0,9
INDUCTANCE per PHASE		mH	1	2	3,8
HOLDING TORQUE		N · m	0,64	1	1,5
ROTOR INERTIA		$g \cdot cm^2$	120	200	480
WEIGHTS		g	500	700	1150
LENGTH (L)		mm	46	54	80
ALLOWABLE OVERHUNG LOAD (DISTANCE FROM END OF SHAFT)	3mm	N	52	52	52
	8mm		65	65	65
	13mm		85	85	85
	18mm		123	123	123
ALLOWABLE THRUST LOAD		N	Lower than motor weight		
INSULATION RESISTANCE		MOhm	100min. (at 500VDC)		
INSULATION CLASS		----	CLASS B (130°C)		
OPERATING TEMPERATURE		°C	0 to 55		

### 4.6.2 Motor Dimension (mm) and Torque Characteristics

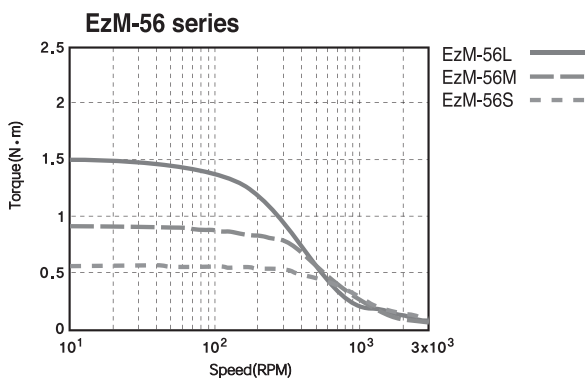
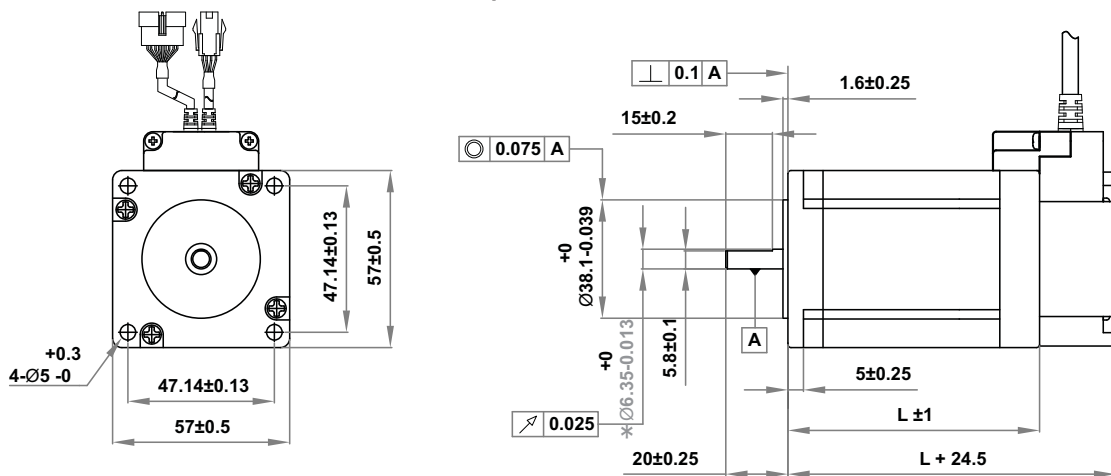

※ Measured Condition

Motor Voltage = 24VDC  
 Motor Current = Rated Current(Refer to Motor Specification)  
 Drive = Ezi-SERVO

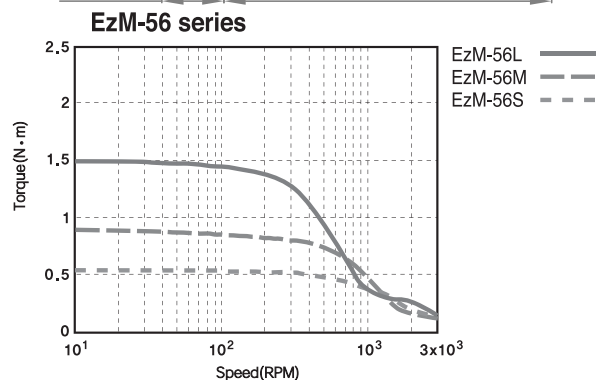

※ Measured Condition

Motor Voltage = 40VDC  
 Motor Current = Rated Current(Refer to Motor Specification)  
 Drive = Ezi-SERVO

\* : There are 2 kinds size of front shaft diameter for EzM-56 series as  $\phi 6,35$  and  $\phi 8,0$ .

## 4.6 EzM-56 Series

### 4.6.1 Motor Specifications

*Low Vibration*

M O D E L	UNIT	EzM-56S-A-L	EzM-56M-A-L	EzM-56L-A-L
		EzM-56S-B-L	EzM-56M-B-L	EzM-56L-B-L
		EzM-56S-C-L	EzM-56M-C-L	EzM-56L-C-L
DRIVE METHOD	----	BI-POLAR	BI-POLAR	BI-POLAR
NUMBER OF PHASES	----	2	2	2
VOLTAGE	VDC	3.36	3.74	4.6
CURRENT per PHASE	A	1.4	2.2	2
RESISTANCE per PHASE	Ohm	2.4	1.7	2.3
INDUCTANCE per PHASE	mH	7.7	7.2	10.6
HOLDING TORQUE	N · m	0.54	1.0	1.5
ROTOR INERTIA	$g \cdot cm^2$	120	200	360
WEIGHTS	g	540	750	1120
LENGTH (L)	mm	42	54	76
ALLOWABLE OVERHUNG LOAD (DISTANCE FROM END OF SHAFT)	3mm	N	52	52
	8mm		65	65
	13mm		85	85
	18mm		123	123
ALLOWABLE THRUST LOAD	N	Lower than motor weight		
INSULATION RESISTANCE	MOhm	100min, (at 500VDC)		
INSULATION CLASS	----	CLASS B (130°C)		
OPERATING TEMPERATURE	°C	0 to 55		

### 4.6.2 Motor Dimension (mm) and Torque Characteristics

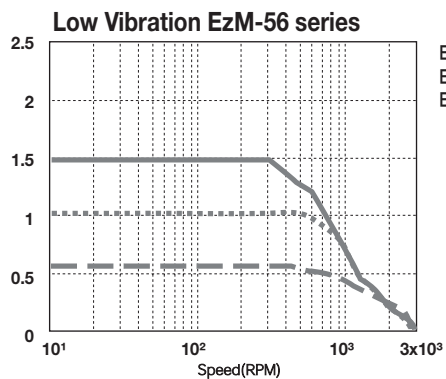
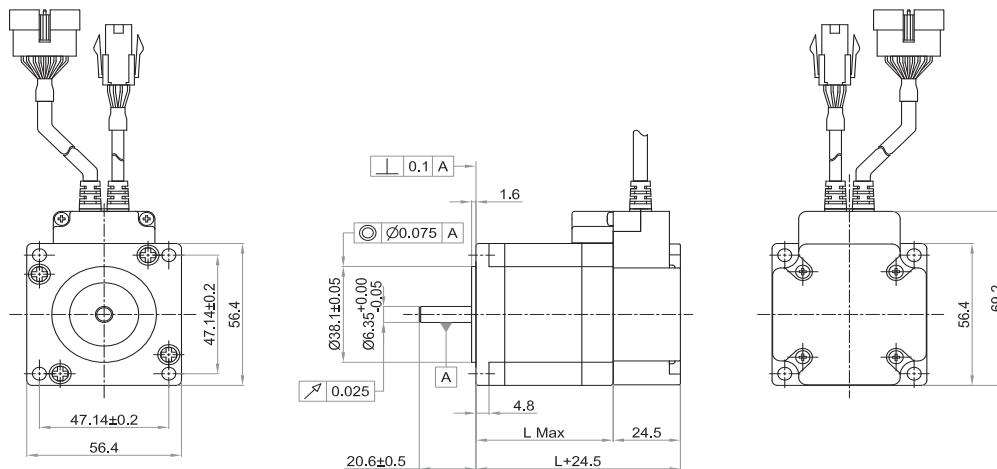

※ Measured Condition  
 Motor Voltage = 24VDC  
 Motor Current = Rated Current(Refer to Motor Specification)  
 Drive = Ezi-SERVO

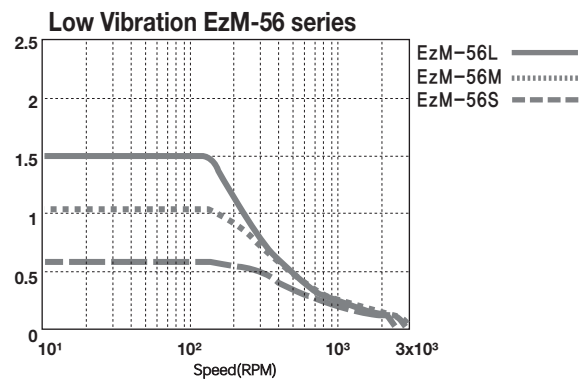

※ Measured Condition  
 Motor Voltage = 40VDC  
 Motor Current = Rated Current(Refer to Motor Specification)  
 Drive = Ezi-SERVO

## 4.8 EzM-60 Series

### 4.8.1 Motor Specifications

M O D E L		UNIT	EzM-60S-A EzM-60S-B EzM-60S-C	EzM-60M-A EzM-60M-B EzM-60M-C	EzM-60L-A EzM-60L-B EzM-60L-C
DRIVE METHOD		----	BI-POLAR	BI-POLAR	BI-POLAR
NUMBER OF PHASES		----	2	2	2
VOLTAGE		VDC	1,52	1,56	2,6
CURRENT per PHASE		A	4	4	4
RESISTANCE per PHASE		Ohm	0,38	0,39	0,65
INDUCTANCE per PHASE		mH	064	1,2	2,4
HOLDING TORQUE		N · m	0,88	1,28	2,4
ROTOR INERTIA		g · cm <sup>2</sup>	140	320	800
WEIGHTS		g	600	900	1600
LENGTH (L)		mm	46	56	90
ALLOWABLE OVERHUNG LOAD (DISTANCE FROM END OF SHAFT)	3mm	N	70	70	70
	8mm		87	87	87
	13mm		114	114	114
	18mm		165	165	165
ALLOWABLE THRUST LOAD		N	Lower than motor weight		
INSULATION RESISTANCE		MOhm	100min. (at 500VDC)		
INSULATION CLASS		----	CLASS B (130°C)		
OPERATING TEMPERATURE		°C	0 to 55		

### 4.8.2 Motor Dimension(mm) and Torque Characteristics

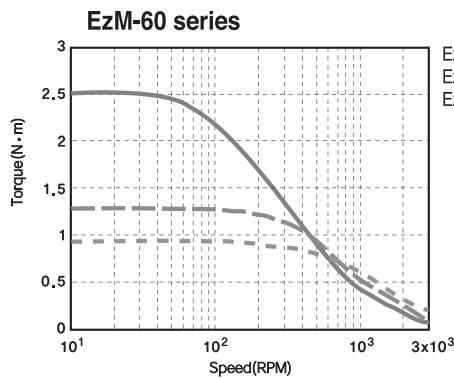
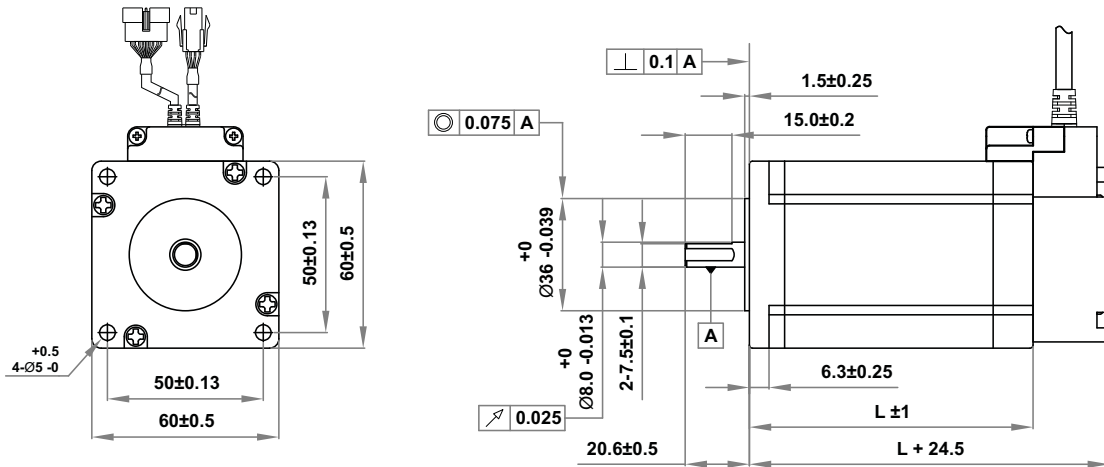

※Measured Condition

Motor Voltage = 24VDC  
 Motor Current = Rated Current(Refer to Motor Specification)  
 Drive = Ezi-SERVO

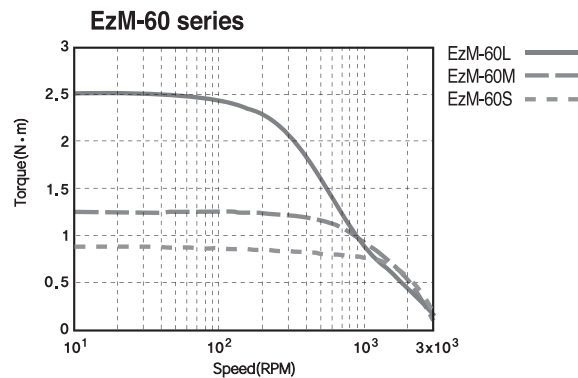

※Measured Condition

Motor Voltage = 40VDC  
 Motor Current = Rated Current(Refer to Motor Specification)  
 Drive = Ezi-SERVO

## 4.9 EzM-71 Series

### 4.9.1 Motor Specifications

*Low Vibration*

M O D E L		UNIT	EzM-71M-A-L EzM-71M-B-L EzM-71M-C-L	EzM-71L-A-L EzM-71L-B-L EzM-71L-C-L
DRIVE METHOD		----	BI-POLAR	BI-POLAR
NUMBER OF PHASES		----	2	2
VOLTAGE		VDC	4.68	4.4
CURRENT per PHASE		A	1.3	2.2
RESISTANCE per PHASE		Ohm	3.6	2
INDUCTANCE per PHASE		mH	11	8.3
HOLDING TORQUE		N · m	1.1	2.1
ROTOR INERTIA		g · cm <sup>2</sup>	330	660
WEIGHTS		g	880	1450
LENGTH (L)		mm	51.5	77.5
ALLOWABLE OVERHUNG LOAD (DISTANCE FROM END OF SHAFT)	3mm	N	70	70
	8mm		87	87
	13mm		114	114
	18mm		165	165
ALLOWABLE THRUST LOAD		N	Lower than motor weight	
INSULATION RESISTANCE		MOhm	100min. (at 500VDC)	
INSULATION CLASS		----	CLASS B (130°C)	
OPERATING TEMPERATURE		°C	0 to 55	

### 4.9.2 Motor Dimension (mm) and Torque Characteristics

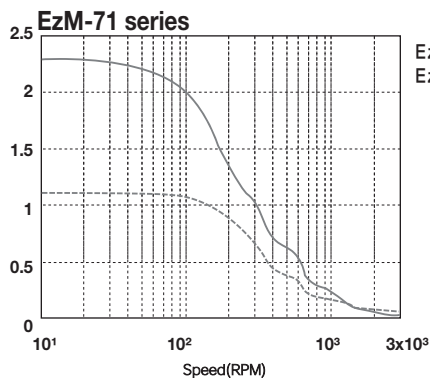
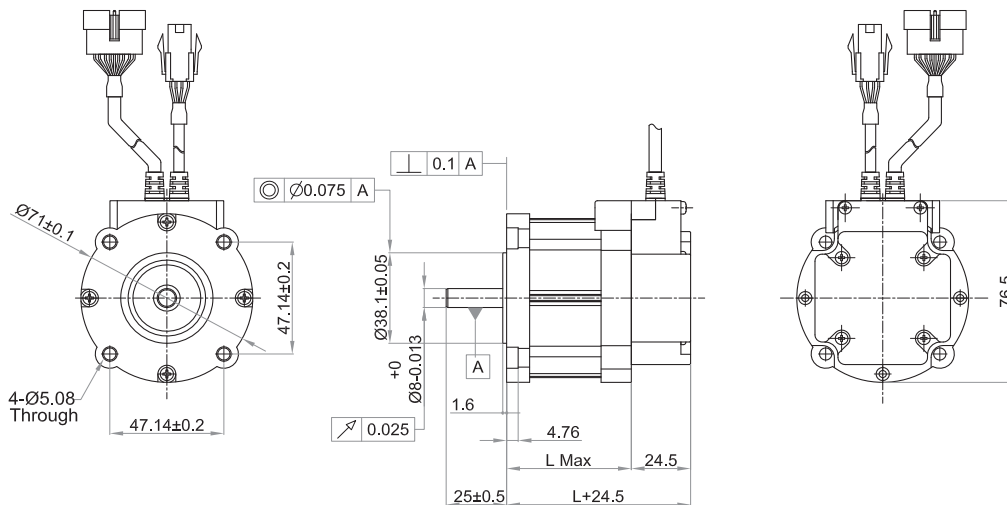

※ Measured Condition  
 Motor Voltage = 24VDC  
 Motor Current = Rated Current(Refer to Motor Specification)  
 Drive = Ezi-SERVO

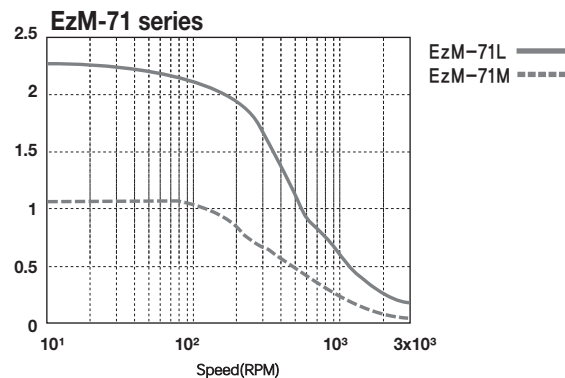

※ Measured Condition  
 Motor Voltage = 40VDC  
 Motor Current = Rated Current(Refer to Motor Specification)  
 Drive = Ezi-SERVO

## 4.10 EzM-86 Series

### 4.10.1 Motor Specifications

M O D E L		UNIT	EzM-86M-A	EzM-86L-A	EzM-86XL-A
DRIVE METHOD		----	BI-POLAR	BI-POLAR	BI-POLAR
NUMBER OF PHASES		----	2	2	2
VOLTAGE		VDC	2.4	3.6	4.38
CURRENT per PHASE		A	6.0	6.0	6.0
RESISTANCE per PHASE		Ohm	0.4	0.6	0.73
INDUCTANCE per PHASE		mH	3.5	6.5	8.68
HOLDING TORQUE		N · m	4.5	8.5	12
ROTOR INERTIA		g · cm <sup>2</sup>	1400	2700	4000
WEIGHTS		Kg	2.4	3.9	5.4
LENGTH (L)		mm	79	119	159
ALLOWABLE OVERHUNG LOAD (DISTANCE FROM END OF SHAFT)	3mm	N	270	270	270
	8mm		300	300	300
	13mm		350	350	350
	18mm		400	400	400
ALLOWABLE THRUST LOAD		N	Lower than motor weight		
INSULATION RESISTANCE		MOhm	100min. (at 500VDC)		
INSULATION CLASS		----	CLASS B (130°C)		
OPERATING TEMPERATURE		°C	0 to 55		

### 4.10.2 Motor Dimension (mm) and Torque Characteristics

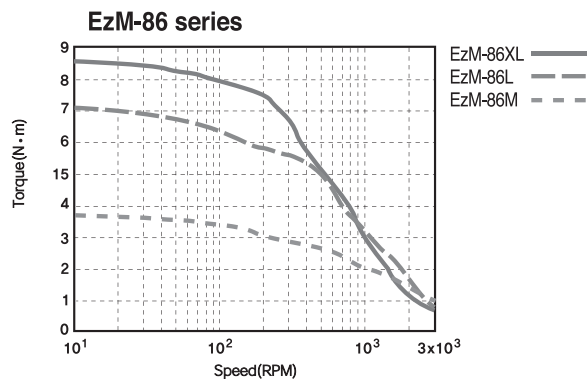
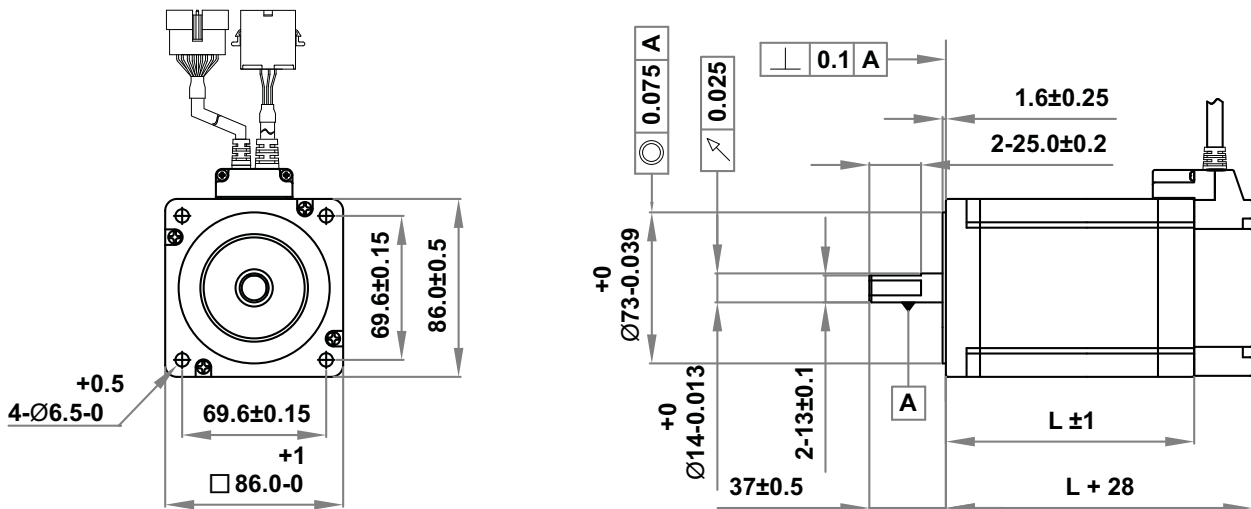

※ Measured Condition

Motor Voltage = 70VDC

Motor Current = Rated Current (Refer to Motor Specification)

Drive = Ezi-SERVO (EzS-PD-86 Series)

## 5. Installation and Cabling

### 5.1 Notes on Installation

- 1) Ezi-SERVO is designed for indoor use only.
- 2) The ambient temperature of the room should be  $0^{\circ}\text{C}\sim 50^{\circ}\text{C}$ .
- 3) If the temperature of the product case is higher than  $50^{\circ}\text{C}$ , radiate heat of the outside to cool down.
- 4) Do not install Ezi-SERVO under direct rays, near magnetic or radioactive objects.
- 5) If you set more than 2 drives, you must set over 20mm horizontally and over 50mm vertically as shown below.

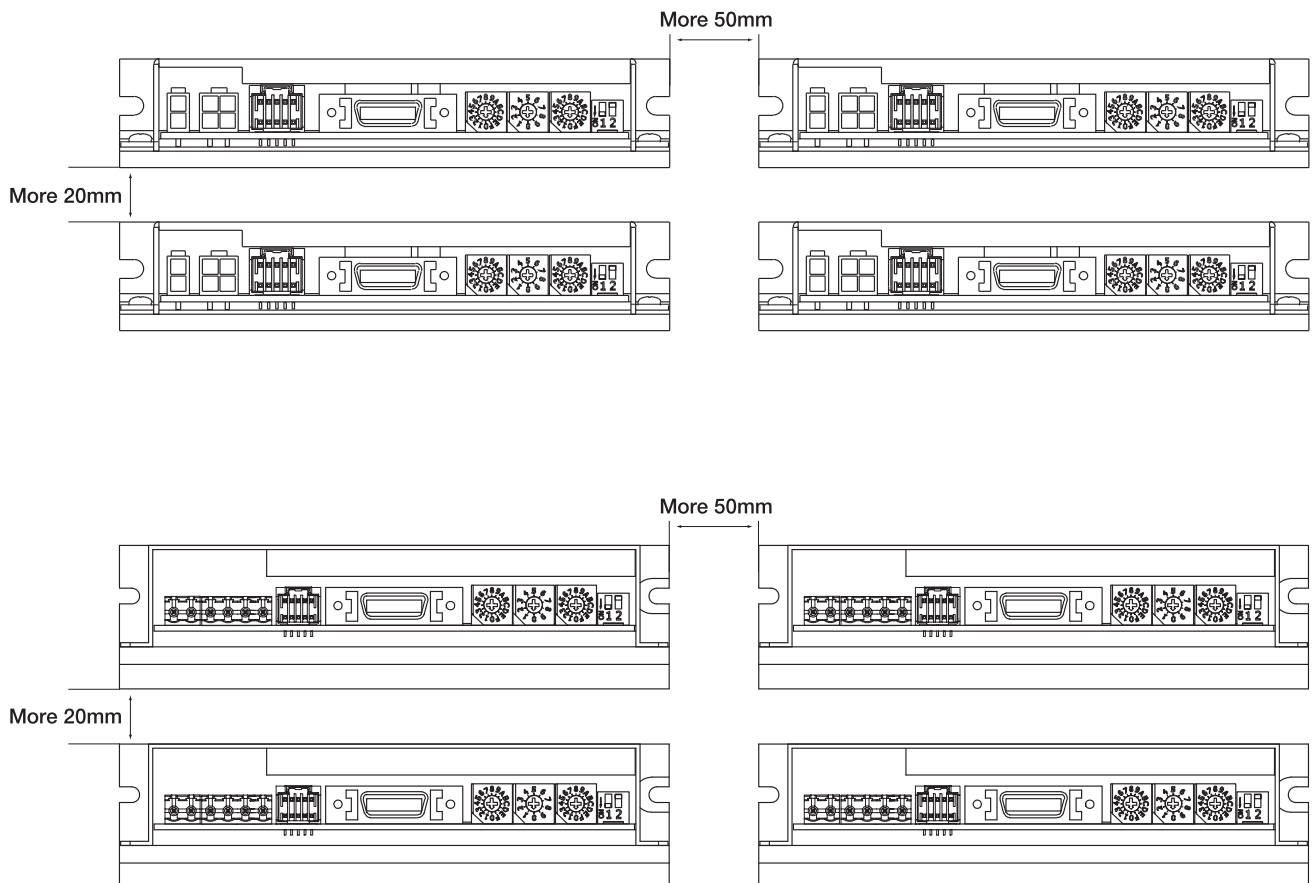

## 5.2 Connection Diagram

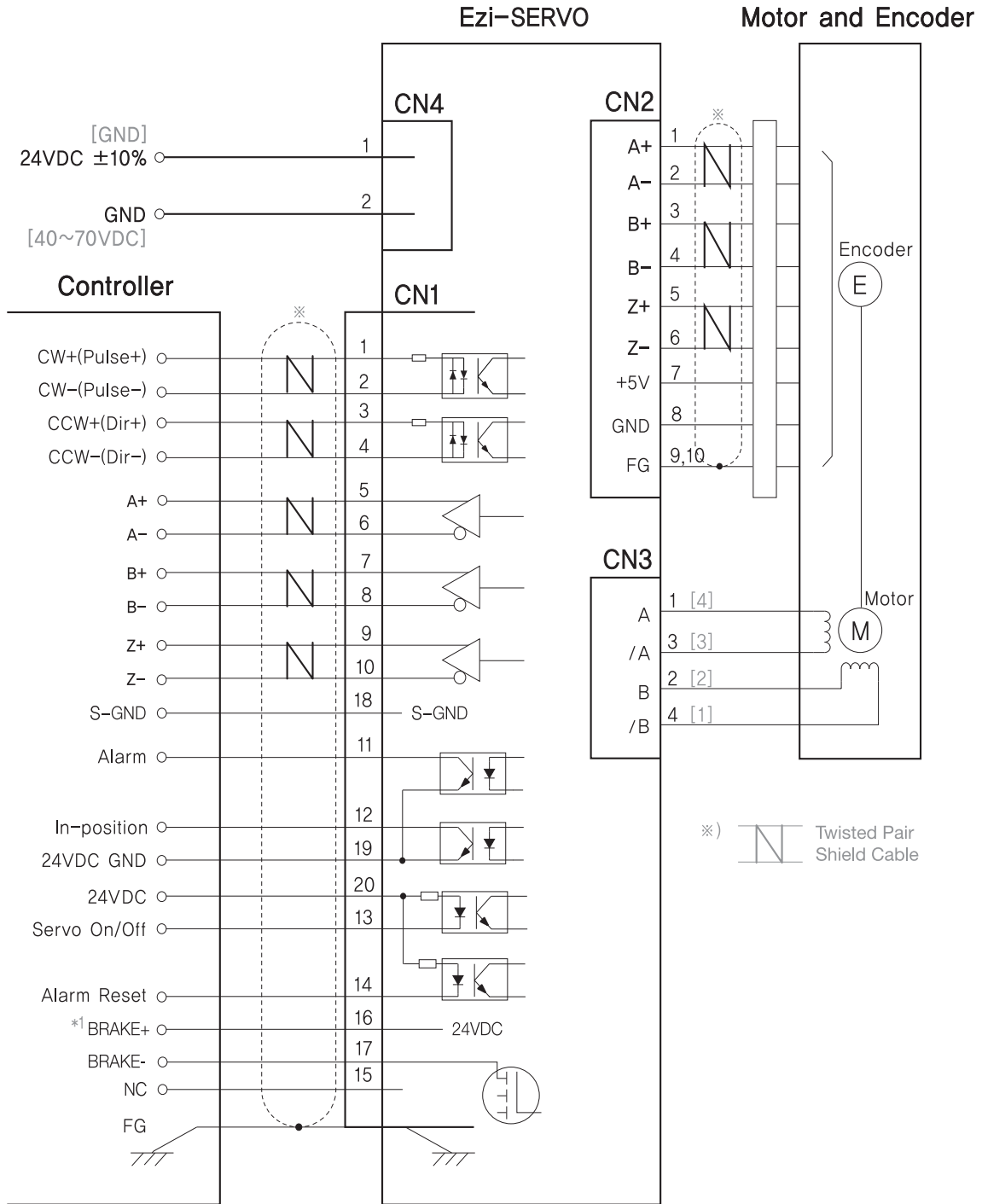

\* Gray color is only 86mm motor drive.(EzM-PD-86 series) Pay attention to gray color that describe the difference.

\* 1 : There is no BRAKE function for 86mm motor drive.

## 6. Setting and Operation

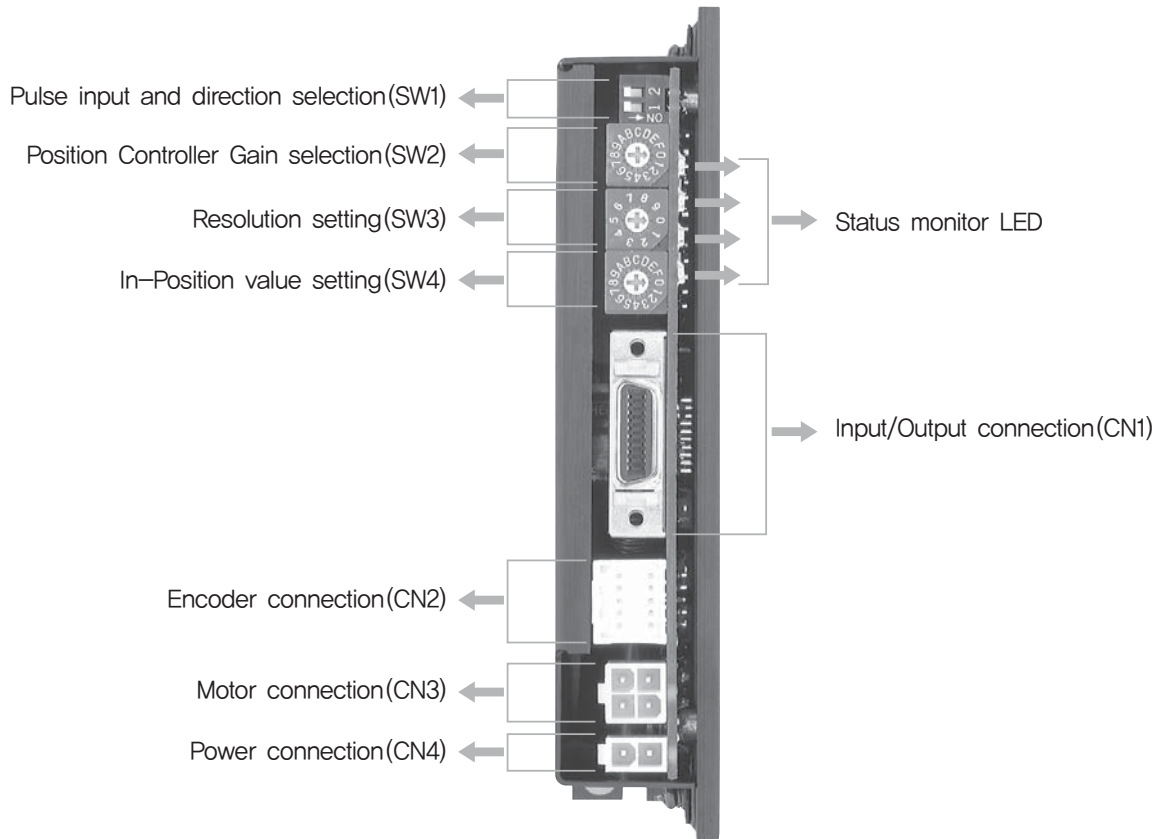

### ◆ 86mm motor drive only (EzS-PD-86 Series)

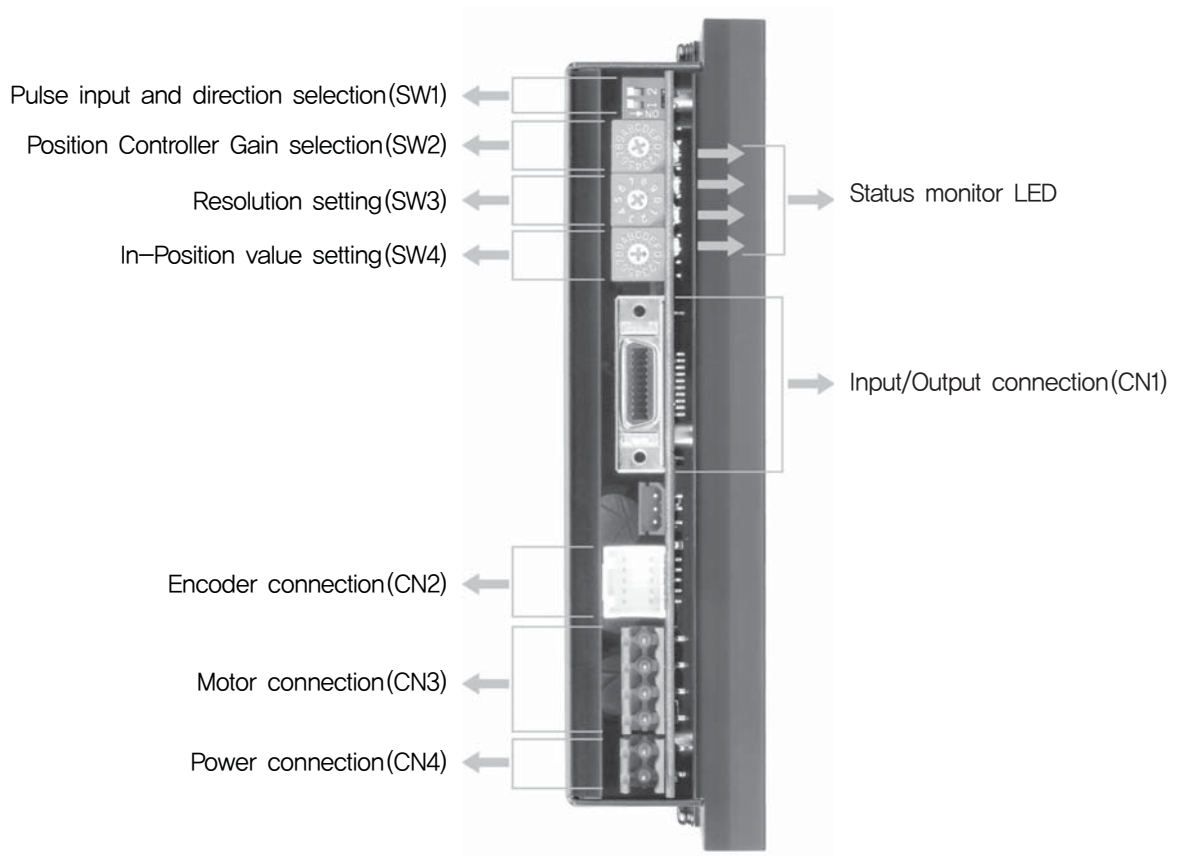



## 6.1 Monitor Status from LEDs

### 6.1.1 Status LED Function and Condition

Status	Color	Function	Flash Condition
PWR	Green	Power input	Lights when power is On
INP	Yellow	Complete position motion	Lights ON when positioning error reaches within the preset pulse selected by rotary switch
SON	Orange	Servo On/Off indication	Servo On : Lights On Servo Off : Lights Off
ALM	Red	Alarm indication	Flash when protection function is activated (Identifiable which protection mode is activated by counting the LED flash times)

### 6.1.2 Protection functions and LED flash times

Times	Protection	Conditions
1	Over current	The current through power devices in inverter exceeds the limit value
2	Over speed	Motor speed exceed 3000rpm
3	Position tracking error	Position error value is higher than 90° in motor run state
4	Over load	The motor is continuously operated more than 5 second under a load exceeding the max. torque
5	Over temperature	Inside temperature of drive exceeds 55°C
6	Over regenerated voltage	Back-EMF more high limit value*1
7	Motor connect error	The power is ON without connection of the motor cable to drive
8	Encoder connect error	Cable connection error with Encoder connector in drive
9	Motor voltage error	Motor voltage is out of limited value*2
10	Inposition error	After operation is finished, a position error occurs
11	System error	Error occurs in drive system
12	ROM error	Error occurs in parameter storage device(ROM)
14	Input voltage error	Power source voltage is out of limited value*3
15	Position overflow error	Position error value is higher than 90° in motor stop state



Alarm LED flash  
(ex : Position tracking error)

Motor	EzM-20, EzM-28, EzM-42, EzM-56, EzM-60	EzM-86
*1 Over regenerated voltage	70V	90V
*2 Motor voltage error	20V	36V
*3 Input voltage error	not support	40V~70V

## 6.2 Pulse input selection switch(SW1.1)

Indication	Switch Name	Functions
2P/1P	Selecting pulse input mode	Selectable 1-Pulse input mode or 2-Pulse input mode as Pulse input signal. ON : 1-Pulse mode OFF : 2-Pulse mode ※Default : 2-Pulse mode

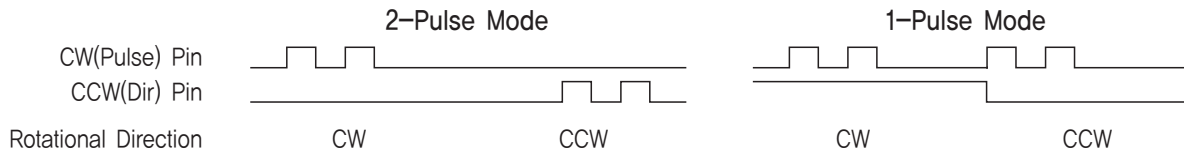

## 6.3 Rotational direction selection switch(SW1.2)

Indication	Switch Name	Functions
DIR	Switching Rotational Direction	Based on CW(+Dir signal) input to driver. ON : CCW(-Direction) OFF : CW(+Direction) ※Default : CW mode

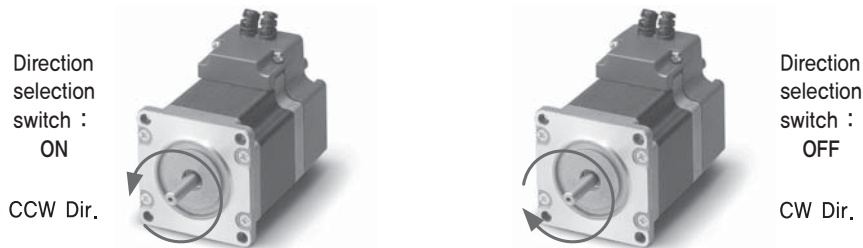

## 6.4 Position Controller Gain select switch(SW2)

The purpose of the Position Controller is to correct motor position deviation after stopping caused by load and friction. Depending on the motor load, the user have to select position of the switch because the system to be stable and to correct the error as fast as possible.

To turn the controller

- 1,Set the switch to '0' position
- 2,Start to rotate the switch until system becomes stable.
- 3,Rotate the switch +/- 1~2 position to reach better performance.

Indica- tion	Time constant of integral part*1	Proportional Gain*1	Indica- tion	Time constant of integral part*1	Proportional Gain*1	
0*2	1	1	8	2	3	
1	1	2	9	2	4	
2	1	3	A	2	5	
3*2	1	4	B	3	1	
4	1	5	C	3	2	
5	1	6	D	3	3	
6	2	1	E	3	4	
7	2	2	F	3	5	

\*1 : Values in the columns are in relative units. They only show the parameter changes depending on the switch's position.

\*2 : Default : '3'

\*3 : This setting can not be used when SW3 and SW4 is set to '0'

## 6.5 Resolution set switch(SW3)

The number of pulse per revolution,

Position	Pulse/Rotation	Position	Pulse/Rotation
0	500* <sup>1</sup>	5	3600
1	500	6	5000
2	1000	7	6400
3	1600	8	7200
4	2000	9	10000* <sup>2</sup>

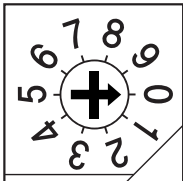

\*1 : Resolution value depend on encoder type.

\*2 : Default : 10000

Resolution value on position '0' depend on Encoder type as follows

Encoder Type	Resolution value on '0' position
A (10000 / revolution)	500
B (20000 / revolution)	20000
C (32000 / revolution)	32000
D (16000 / revolution)	16000
F (4000 / revolution)	4000

## 6.6 In-Position value set switch(SW4)

To select the output condition of In-position signal, In-position output signal is generated when the pulse number of position error is lower than selected In-position value set by this switch after positioning command executed.

Indication	In-Position [Pulse] Fast Response	Indication	In-Position [Pulse] Accurate Response
* <sup>1</sup> 0	0	8	0
1	1	9	1
2	2	A	2
3	3	B	3
4	4	C	4
5	5	D	5
6	6	E	6
7	7	F	7

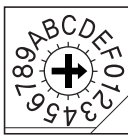

\*1 : Default : '0'

### 6.6.1 Setting method of Fast Response and Accurate Response

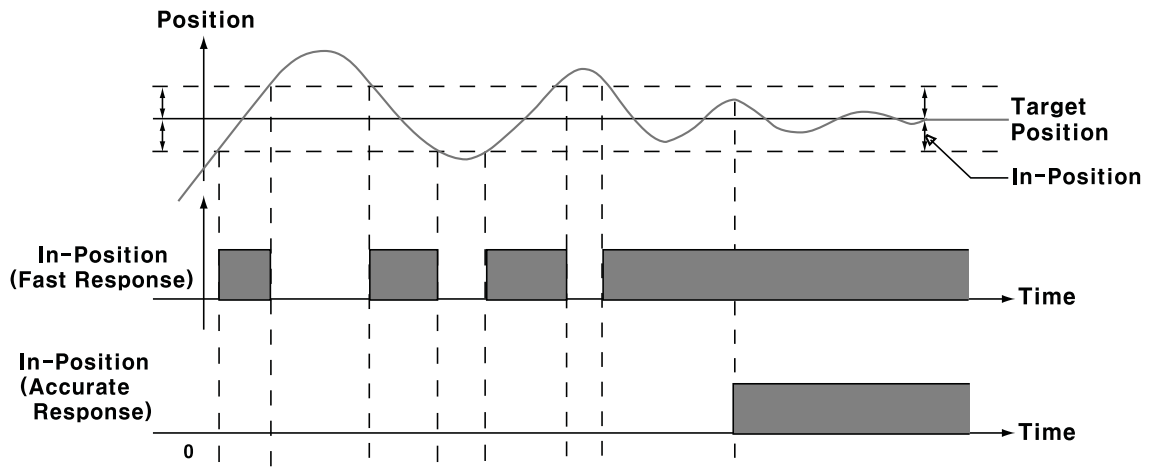

### 6.7 Motor Connector (CN3)

Indication	Function	
1	A Phase	
2	B Phase	
3	/A Phase	
4	/B Phase	

◆ Only for 86mm motor drive

Indication	Function	
1	/B Phase	
2	B Phase	
3	/A Phase	
4	A Phase	

### 6.8 Power Connector (CN4)

Indication	Function	
1	Input Power : 24VDC $\pm$ 10%	
2	Input Power : GND	

◆ Only for 86mm motor drive

Indication	Function	
1	Input Power : GND	
2	Input Power : 40~70VDC	

## 6.9 Control signal Input/Output Connector (CN1)

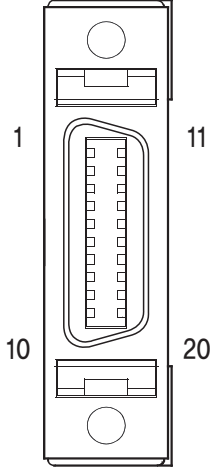
Indication	Function	I/O	
1	CW+(Pulse+)	Input	
2	CW-(Pulse-)	Input	
3	CCW+(Dir+)	Input	
4	CCW-(Dir-)	Input	
5	A+	Output	
6	A-	Output	
7	B+	Output	
8	B-	Output	
9	Z+	Output	
10	Z-	Output	
11	Alarm	Output	
12	In-Position	Output	
13	Servo On/Off	Input	
14	Alarm Reset	Input	
15	NC	----	
16	BRAKE+	Output	
17	BRAKE-	Output	
18	S-GND	Output	
19	24VDC GND	Input	
20	24VDC	Input	

※ BRAKE function is Optional.

※ There is no BRAKE function for 86mm motor drive

## 6.10 Encoder Connector (CN2)

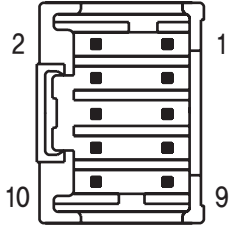
Indication	Function	I/O	
1	A+	Input	
2	A-	Input	
3	B+	Input	
4	B-	Input	
5	Z+	Input	
6	Z-	Input	
7	5VDC	Output	
8	5VDC GND	Output	
9	Frame GND	----	
10	Frame GND	----	

## 6.11 Run Current

There's no need to adjust because the run current is set with comparing to the kind of motor. But, the run current is 50% when motor is stopped.

## 7. System Configuration

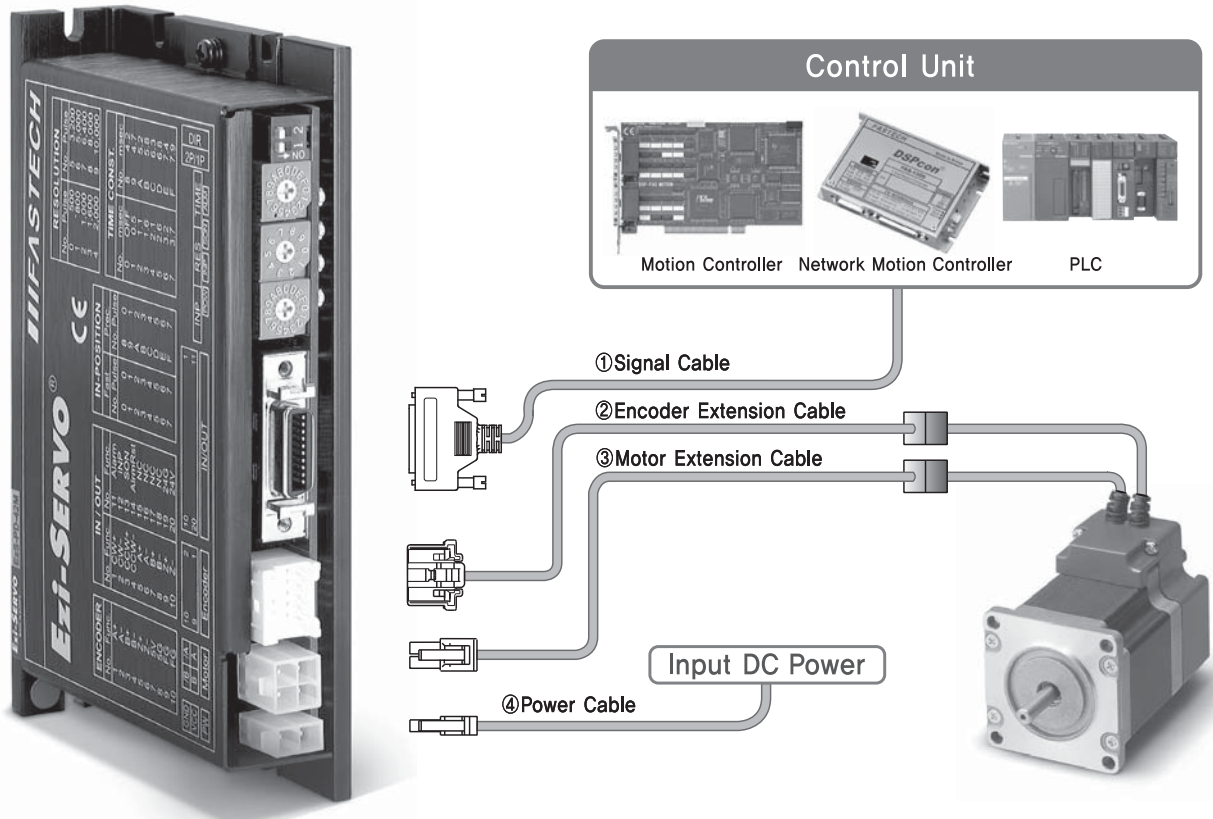

Type	Power Cable	Motor Cable	Encoder Cable	Signal Cable
Standard Length	-	30cm	30cm	-
Max. Length	2m	20m	20m	20m

\* Standard cable length of Motor and Encoder is 30cm, Extension Cable is needed to extend this limitation(OPTION)

### 7.1 Cable Option

#### ① Signal Cable

Available to connect between Control System and Ezi-SERVO.

Item	Length[m]	Remark
CSVO-S-□□□F	□□□	Normal Cable
CSVO-S-□□□M	□□□	Robot Cable

□ is for Cable Length, The unit is 1m and Max, 20m length.

#### ③ Motor Extension Cable

Available to extended connection between motor and Ezi-SERVO.

Item	Length[m]	Remark
CSVO-M-□□□F	□□□	Normal Cable
CSVO-M-□□□M	□□□	Robot Cable

□ is for Cable Length, The unit is 1m and Max, 20m length.

#### ② Encoder Extension Cable

Available to extended connection between motor and Ezi-SERVO.

Item	Length[m]	Remark
CSVO-E-□□□F	□□□	Normal Cable
CSVO-E-□□□M	□□□	Robot Cable

□ is for Cable Length, The unit is 1m and Max, 20m length.

#### ④ Power Cable

Available to extended connection between motor and Ezi-SERVO.

Item	Length[m]	Remark
CSVO-P-□□□F	□□□	Normal Cable
CSVO-P-□□□M	□□□	Robot Cable

□ is for Cable Length, The unit is 1m and Max, 2m length.

## 8. System Configuration[Only for 86mm motor drive(EzS-PD-86 Series)]

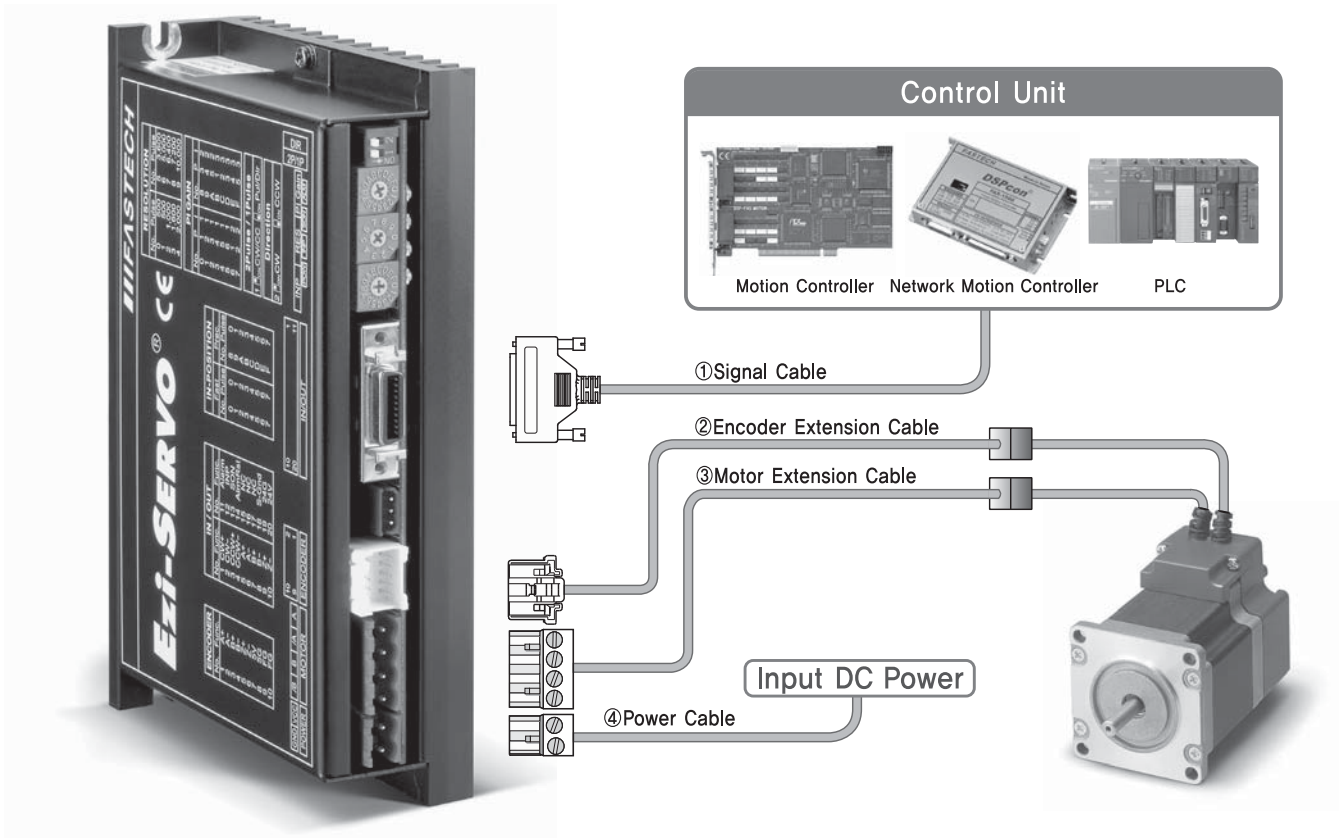

Type	Power Cable	Motor Cable	Encoder Cable	Signal Cable
Standard Length	—	30cm	30cm	—
Max. Length	2m	20m	20m	20m

※ Standard cable length of Motor and Encoder is 30cm, Extension Cable is needed to extend this limitation(OPTION)

### 8.1 Cable Option

#### ① Signal Cable

Available to connect between Control System and EzI-SERVO.

Item	Length[m]	Remark
CSVO-S-□□□F	□□□	Normal Cable
CSVO-S-□□□M	□□□	Robot Cable

□ is for Cable Length. The unit is 1m and Max, 20m length.

#### ③ Motor Extension Cable

Available to extended connection between motor and EzI-SERVO.

Item	Length[m]	Remark
CSVP-M-□□□F	□□□	Normal Cable
CSVP-M-□□□M	□□□	Robot Cable

□ is for Cable Length. The unit is 1m and Max, 20m length.

#### ② Encoder Extension Cable

Available to extended connection between motor and EzI-SERVO.

Item	Length[m]	Remark
CSVO-E-□□□F	□□□	Normal Cable
CSVO-E-□□□M	□□□	Robot Cable

□ is for Cable Length. The unit is 1m and Max, 20m length.

#### ④ Power Cable

Available to extended connection between motor and EzI-SERVO.

Item	Length[m]	Remark
CSVP-P-□□□F	□□□	Normal Cable
CSVP-P-□□□M	□□□	Robot Cable

□ is for Cable Length. The unit is 1m and Max, 2m length.

## 9. Control signal Input/Output Description

### 1 Input Signal

Input signals of the drive are all photocoupler inputs. The signal shows the status of internal photocouplers [ON : conduction], [OFF : Non-conduction], not displaying the voltage levels of the signal.

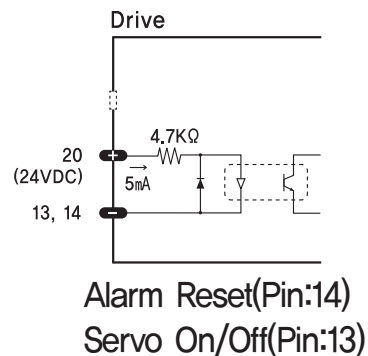
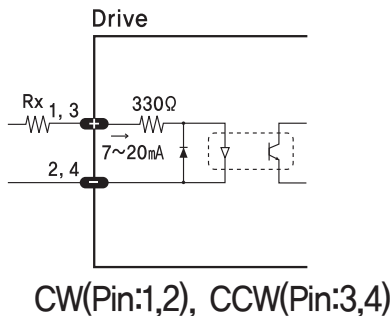

#### ◆CW, CCW Input

This signal can be used to receive a positioning pulse command from a user host motion controller. A user can select 1-pulse input mode or 2-pulse input mode (refer to switch No.1, SW1).

The input schematic of CW, CCW is designed for 5V TTL level. When using 5V level as an input signal, the resistor Rx is not used and connect to the driver directly.

When the level of input signal is more than 5V, Rx Resistor is required. If the resistor is absent, the drive will be damaged! In input signal level is 12V case, Rx value is 2.2kohm and in 24V case, 4.7kohm is suitable for Rx value.

#### ◆Servo On/Off Input

This input can be used only to adjust the position by manually moving the motor shaft from the load-side. By setting the signal [ON], the driver cuts off the power supply to the motor. Then, one can manually adjust output position. When setting the signal back to [OFF], the driver resumes the power supply to the motor and recovers the holding torque. When driving a motor, one needs to set the signal [OFF].

#### ◆Alarm Reset Input

When a protection mode has been activated, a signal to this alarm reset input cancels the Alarm output.

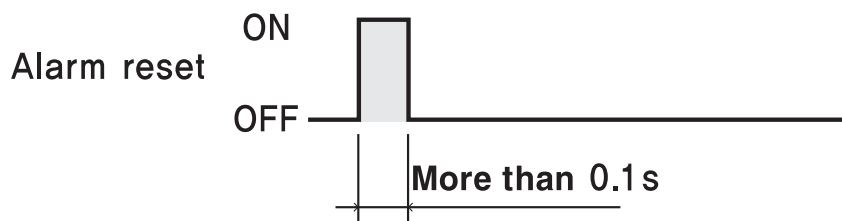

※ By setting the alarm reset input signal [ON], cancel the Alarm output. Before cancel the Alarm output, have to remove the source of Alarm.



## 2 Output Signal

Output signals from the driver are photocoupler outputs : Alarm, In-Position and the line driver outputs(encoder signal). In the case of photocoupler outputs, the signal indicates the status of internal photocouplers [ON: conduction], [OFF: Non-conduction], not displaying the voltage levels of the signal.

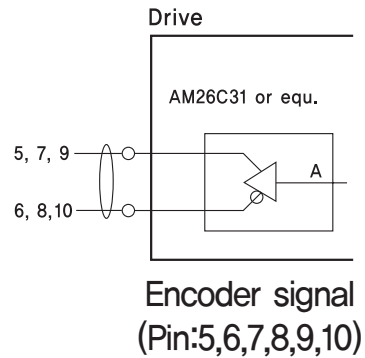
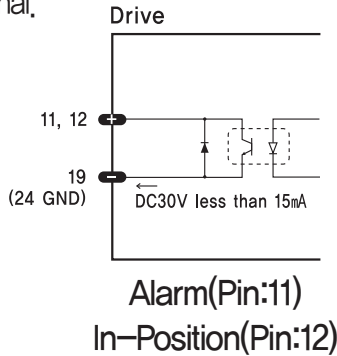

### ◆Alarm Output

The Alarm output indicates [ON] when the driver is in a normal operation. If a protection mode has been activated, it goes [OFF]. A host controller needs to detect this signal and stop sending a motor driving command. When the driver detects an abnormal operation such as overload or overcurrent of the motor, it sets the Alarm output to [OFF], blinks the Alarm LED, disconnect the power to a motor and stop the motor simultaneously.

**[Caution]** Only at the Alarm output port, the photocoupler operation is in reverse. When the driver is in normal operation the Alarm output is [ON]. On the contrary when the driver is in abnormal operation that start protection mode, the Alarm output is [OFF].

### ◆In-Position Output

In-Position signal is [ON] when positioning is completed. This signal is [ON] when the motor position error is within the value set by the switch SW4

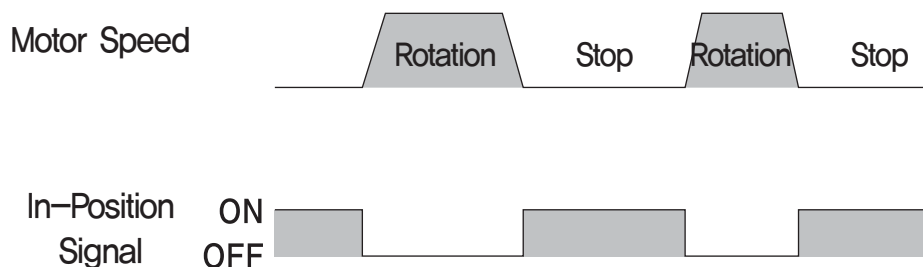

**[Caution]** In-Position signal is [ON] when low speed(under 50[pps]) Motioning even if The position command is not finished.

### ◆Encoder signal Output

The encoder signal is a line drive output. This can be used to confirm the stop position.

## Appendix

### ■ Extension cable for Motor

For cable extension between Motor and Drive.

#### WIRING DIAGRAM

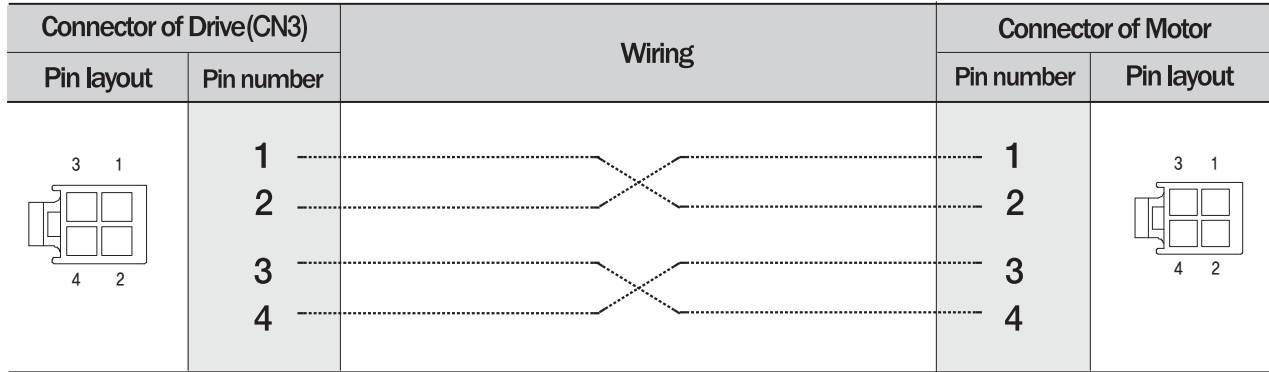

#### CONNECTOR

ITEM	Part Number	Maker
Housing	5557-04R	MOLEX
Terminal	5556T	MOLEX

#### WIRING DIAGRAM(86mm drive only)

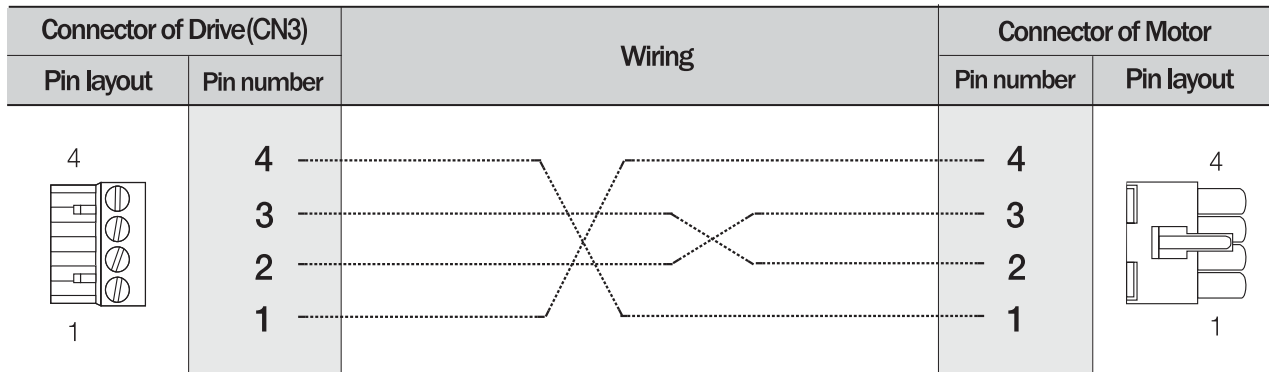

#### CONNECTOR(86mm drive only)

ITEM	Part Number	Maker
Drive Connector(CN3)	Terminal Block	AK950-4 PTR
Motor Connector	Housing Terminal	3191-4RI 1381T MOLEX MOLEX

## ■ Extension cable for Encoder

For cable extension between Encoder and Drive.

### WIRING DIAGRAM

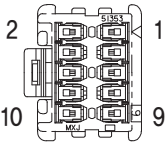
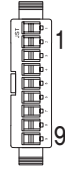
Connector of Drive(CN2)		Wiring	Connector of Motor	
Pin layout	Pin number		Pin number	Pin layout
	1	-----	1	
	2	-----	2	
	3	-----	3	
	4	-----	4	
	5	-----	5	
	6	-----	6	
	7	-----	7	
	8	-----	8	
	9	-----	9	
	10			

### CONNECTOR

ITEM		Part Number	Maker
Drive Connector(CN2)	Housing	51353-1000	MOLEX
	Terminal	56134-9000	MOLEX
Motor Connector	Housing	SMP-09V-NC	JST
	Terminal	SHF-001T-0,8BS	JST

## ■ Connector

Connector specifications for cabling to Ezi-SERVO.

ITEM		Part Number	Maker		
Power(CN4)	Housing Terminal	5557-02R 5556T	MOLEX MOLEX		
	Terminal Block	AK950-2	PTR	86mm motor drive only	
Motor	Drive Side (CN3)	Housing Terminal	5557-04R 5556T	MOLEX MOLEX	
		Terminal Block	AK950-4	PTR	86mm motor drive only
	Motor Side	Housing Terminal	5557-04R 5556T	MOLEX MOLEX	
		Housing Terminal	3191-4RI 1381T	MOLEX MOLEX	86mm motor drive only
Encoder	Drive Side (CN2)	Housing Terminal	51353-1000 56134-9000	MOLEX MOLEX	
	Encoder Side	Housing Terminal	SMP-09V-NC SHF-001T-0,8BS	JST JST	
Signal (CN1)	Connector Backshell	10120-3000VE 10320-52AO-008	3M 3M		

※ These connectors are serviced together with Ezi-SERVO except when purchasing option cables.

※ Above connector is the most suitable product for Ezi-SERVO. Another equivalent connector can be used.

## Advantages over Open-loop Control Stepping Drive

1. Reliable positioning without loss of synchronism.
2. Holding stable position and automatically recovering to the original position even after experiencing positioning error due to a external force, such as mechanical vibration or vertical positioning holding.
3. Ezi-SERVO utilizes 100% full range of the rated motor torque, contrary to a conventional open-loop stepping drive that can use only up to 50% of the rated motor torque by considering loss of synchronism.
4. Capability to operate at high speed due to load-dependent current control, open-loop stepper drives use a constant current control at all speed range without considering load variations.

## Advantages over servo motor controller

1. No gain tuning (Automatic adjustment of gain in response to a load change)
2. Maintain the stable holding position without fluctuation after completing positioning.
3. Fast positioning due to the independent control by on-board DSP.
4. Continuous operation during rapid short-stroke movement due to instantaneous positioning.

**MEMO**



**FASTECH Co., Ltd.**

Rm #1202, Bucheon Technopark 401 Dong, Yakdeok-dong,  
Wonmi-Gu, Bucheon-si, Gyeonggi-do, Rep. Of Korea (Zip)420-734  
TEL : 82-32-234-6300,6301 FAX : 82-32-234-6302  
E-mail : daniel@fastech.co.kr website: www.fastech.co.kr

• Please note that the specifications are subject to change without notice due to product improvements.

© Copyright FASTECH CO., LTD, Jan 31, 2012 Rev. 08